

PMA8000 Connector, J1 (Sub-D 44-pin, male on tray)

Notes:

1. All shields should be grounded at audio panel only. Other end remains floating.
2. All Power, and Ground wires must be #18 gage wire Lighting #22 AWG, other wires minimum #24 AWG
3. All mic and headphone jacks must be isolated from ground.
4. Speaker loads may be required on some older transceivers. Consult manufacturer's information.
COM 2 Speaker load is the only one provided in the PMA8000.
5. All shielded wires must be MIL 22750 or 27500.
6. Unswitched inputs are always presented to speaker and crew headphones, regardless of SPR switch or PTT.
7. COM active output provides a logic low when there is activity on COMs or other selected audio. This is used to prioritize audio warnings in some systems.
8. No connection to pins 23, 25, and 26

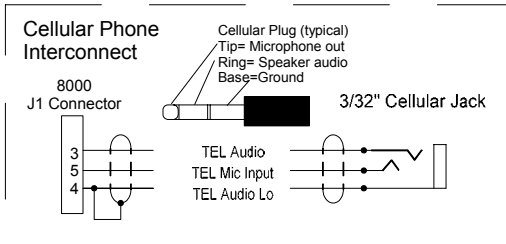
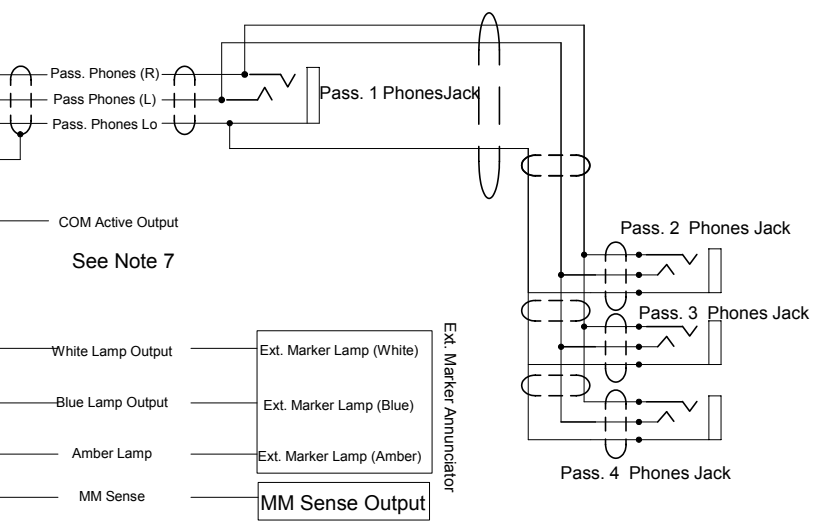
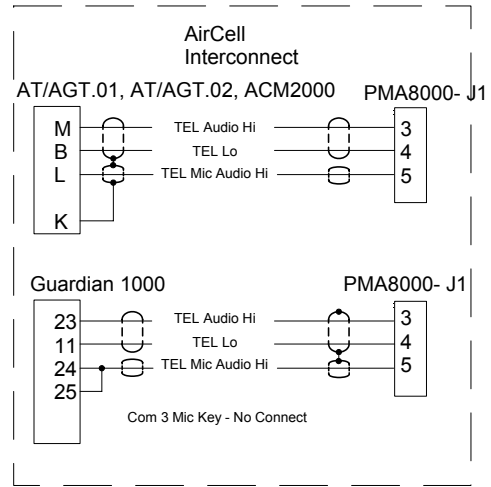
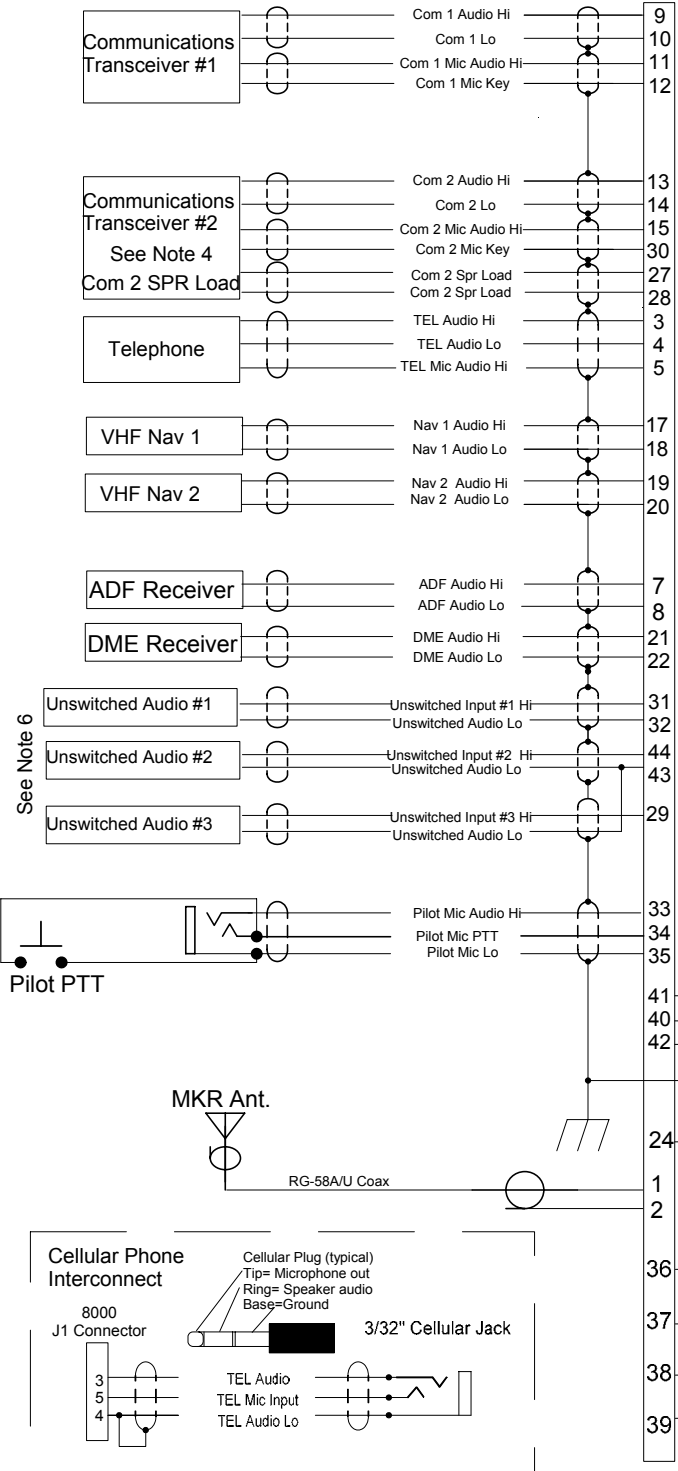

DWN	GLP	AS ENGINEERING [®] INCORPORATED
DATE	1/06/04	
CKD	RSH	9800 MARTEL ROAD, LENOIR CITY TN 37772
DATE	1/16/04	TITLE: PMA8000 J1 Wiring
APR	RSH	SIZE: DOCUMENT NUMBER: 120-891-0104
DATE	1/16/04	REV: 2
Rev 2	5/20/04	DATE: 1/6/04 SHEET1 OF1

PMA8000 J2 CONNECTOR
(Sub-D 44-pin male on tray)

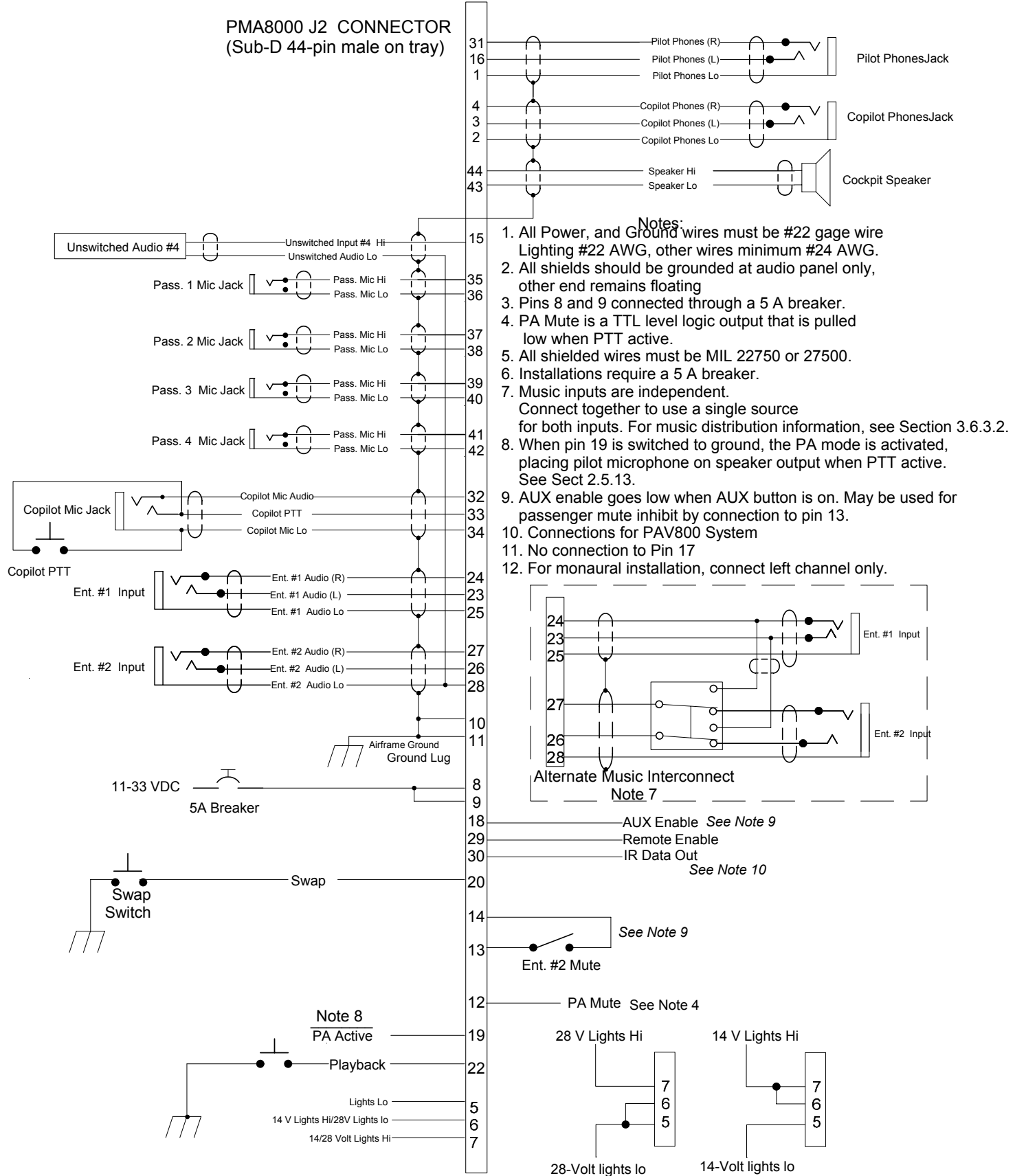

- Notes:**
1. All Power, and Ground wires must be #22 gage wire Lighting #22 AWG, other wires minimum #24 AWG.
 2. All shields should be grounded at audio panel only, other end remains floating
 3. Pins 8 and 9 connected through a 5 A breaker.
 4. PA Mute is a TTL level logic output that is pulled low when PTT active.
 5. All shielded wires must be MIL 22750 or 27500.
 6. Installations require a 5 A breaker.
 7. Music inputs are independent. Connect together to use a single source for both inputs. For music distribution information, see Section 3.6.3.2.
 8. When pin 19 is switched to ground, the PA mode is activated, placing pilot microphone on speaker output when PTT active. See Sect 2.5.13.
 9. AUX enable goes low when AUX button is on. May be used for passenger mute inhibit by connection to pin 13.
 10. Connections for PAV800 System
 11. No connection to Pin 17
 12. For monaural installation, connect left channel only.

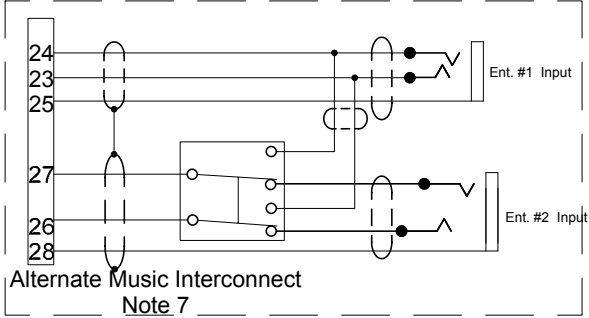

Alternate Music Interconnect
Note 7

18 — AUX Enable See Note 9
 29 — Remote Enable
 30 — IR Data Out
 See Note 10

14 — See Note 9
 13 — Ent. #2 Mute

12 — PA Mute See Note 4

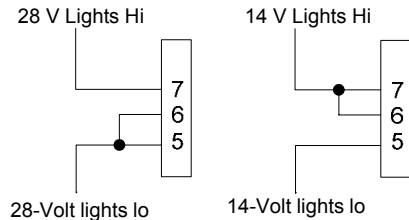

Note 8
 PA Active

Playback

Lights Lo
 14 V Lights Hi/28V Lights lo
 14/28 Volt Lights Hi

DWN	GLP	RS ENGINEERING INCORPORATED
DATE	1/6/04	
CKD	RSH	9800 MARTEL ROAD, LENOX CITY, TN 37772
DATE	1/16/04	TITLE: PMA8000 J2 Wiring
APR	RSH	SIZE DOCUMENT NUMBER: REV
DATE	1/16/04	A 120-892-0104 3
Rev 3	5/18/04	DATE: 04/06/04 SHEET1 OF1