



Installation Manual

For
8300-013 Rev C
Automatic Pitch Trim



TRUTRAK FLIGHT SYSTEMS

1500 S. Old Missouri Road
Springdale, AR 72764
Ph: 479-751-0250 Fax: 479-751-3397

www.trutrakap.com

**IT IS THE INSTALLERS RESPONSIBILITY TO ENSURE
THAT THE TRIM SYSTEM DOES NOT EXCEED THE
ABILITY OF THE PILOT TO CONTROL THE AIRCRAFT AT
ANY SPEED WITH THE TRIM TAB AT FULL DEFLECTION
IN EITHER POSITION.**

**IF UNABLE TO MAINTAIN FLIGHT CONTROL WITH THE
TRIM TABS AT FULL DEFLECTION THEN STOPS WILL BE
NEEDED IN THE AIRCRAFT TRIM SYSTEM.**

Table of Contents

Electrical Pin-Out	1
Automatic Pitch Trim Ground Checkout	2
Retrofit to existing autopilot harness	3
Pitch Auto Trim Block Diagram	3
Roll Auto Trim Block Diagram	4
28 Volt Aircraft with 12 Volt Trim System	4
Manual Auto Trim Switching	5
Trouble Shooting	5
RETURN MERCHANDISE POLICY	6

Revision	Date	Description	Pages
C	12/22/2009	New auto trim module	All

Electrical Pin-Out

The table below provides a brief explanation of each pin function on the 25-pin connector P101.

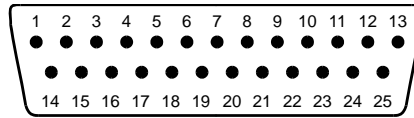

25-Pin Connector P101

P101 Pin	Function	Notes
1	No Connection. Reserved for future expansion.	
2	No Connection. Reserved for future expansion.	
3	Pitch Servo Trim Sensor. Pitch servo trim sensor output to autopilot programmer.	@2.5 v AP engaged no load
4	Pitch Servo Trim Sensor. Pitch servo trim sensor input from pitch servo pin 7.	@2.5 v AP engaged no load
5	Torque Control. Pitch servo torque control input from autopilot programmer.	@5 volt, AP engaged
6	Torque Control. Pitch servo torque control output to pitch servo.	@5 volt, AP engaged
7	No Connection. Reserved for future expansion.	
8	Trim Switch 1. Line 1 to existing trim switch.	
9	Motor 1. Line 1 to existing trim servo motor. Will not control relays	Voltage in @max 5 amps
10	Motor 2. Line 2 to existing trim servo motor. Will not control relays	Voltage in @max 5 amps
11	Trim Switch 2. Line 2 to existing trim switch.	
12	Power. Connects to autopilot master or pitch servo power line from programmer.	11 – 35V input
13	Power. Connects to pitch servo pin 1.	
14	Ground. Ground connection to link sensor.	
15	Ground. Connect to aircraft ground.	Aircraft ground
16	Ground. Ground connection to pitch servo pin 9.	
17	No Connection. Reserved for future expansion.	
18	PH1P. Servo drive line output to pitch servo pin 3.	
19	PH1P. Servo drive line input from programmer	
20	PH1N. Servo drive line output to pitch servo pin 2.	
21	PH1N. Servo drive line input from programmer	
22	PH2P. Servo drive line output to pitch servo pin 5.	
23	PH2P. Servo drive line input from programmer	
24	PH2N. Servo drive line output to pitch servo pin 4.	
25	PH2N. Servo drive line input from programmer	

The Auto Trim controller **MUST** be wired directly to the aircraft trim motor. If the aircraft manual trim system uses a relay system the Auto Trim connects on the motor side of the relay system.

Total Weight	Voltage	Current	Trim Motor Output
.5 LB	11 V – 35 V	.25 A – 5 A	Input voltage / 5 Amps

Automatic Pitch Trim Ground Checkout

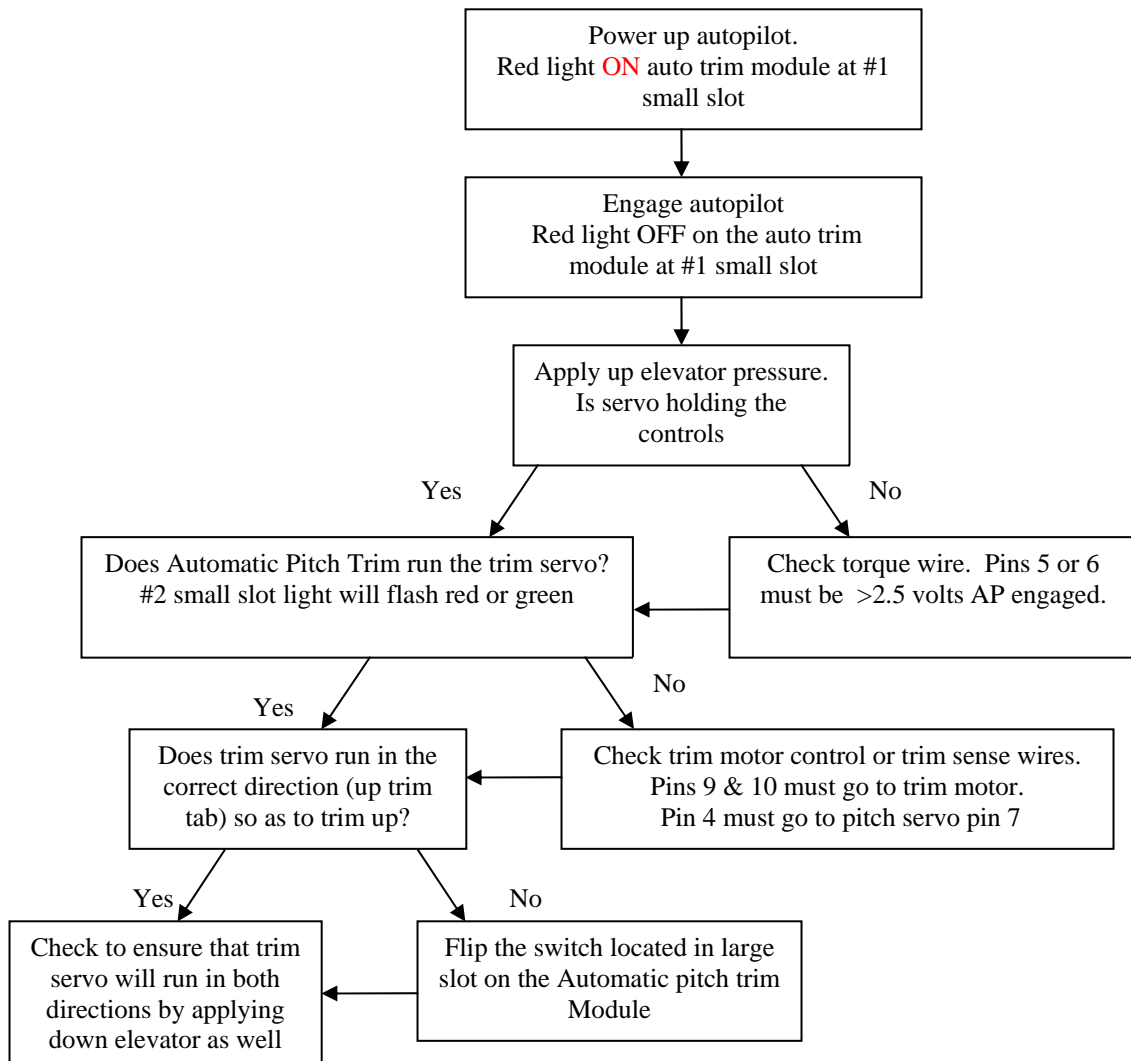

Note: If the above technique has been completed and the automatic trim module still does not run the trim, then first try applying more force to the system when holding the up elevator. If the pitch servo slips easily when holding the force, ensure that the pitch servo torque is set at the maximum value and hold as much force as possible without slipping the servo. If the torque is set at the maximum and the system still does not function, check automatic trim wiring.

The switch in the first slot of the controller is to switch trim motor direction, see above diagram.

Two small slots are control indication Led's, see above.

Potentiometer located on the side of the controller is used to adjust the speed of trim motor rate of change, clockwise rotation to increase speed. Too little of rate will cause trim indicator to show on auto pilot display. If rate setting is too fast then aircraft will hunt in pitch.



Retrofit to existing autopilot harness

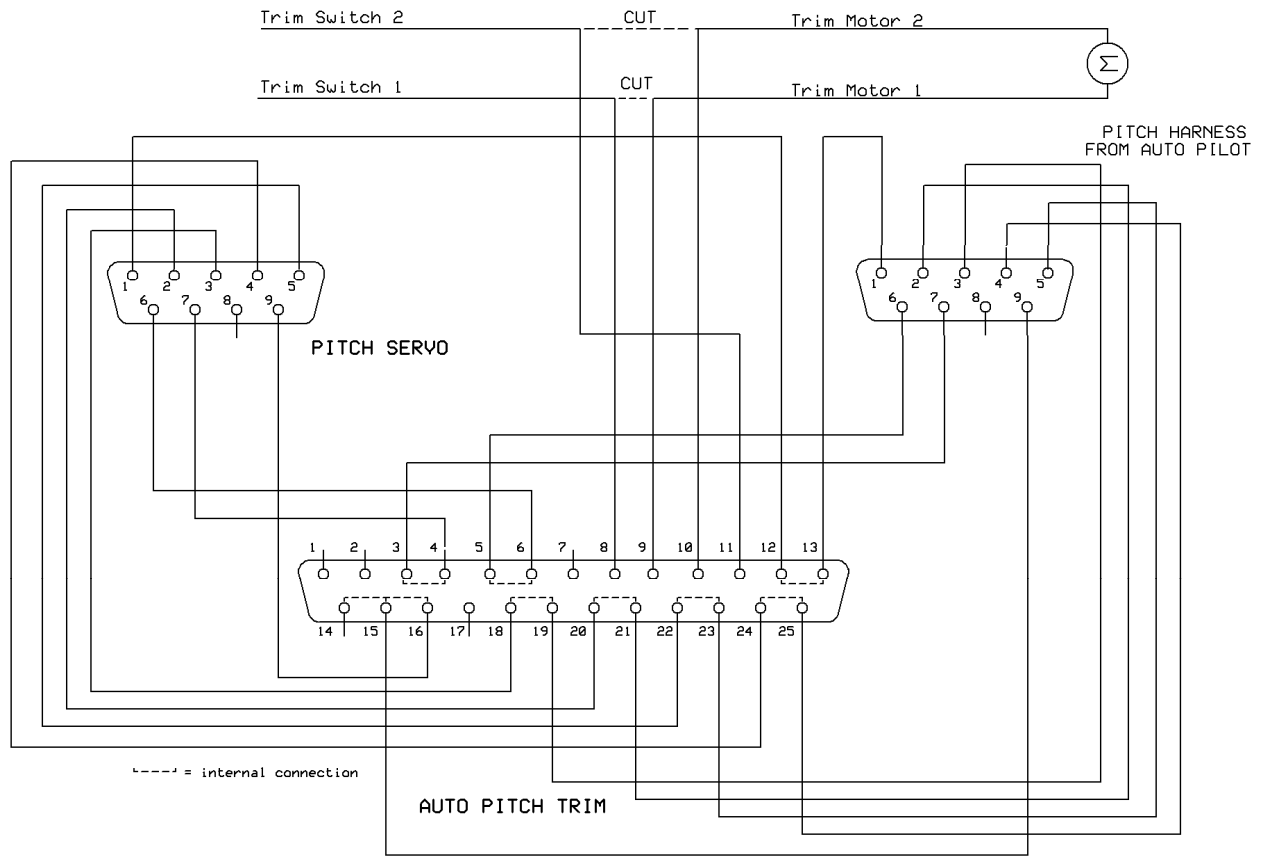

Pitch Auto Trim Block Diagram

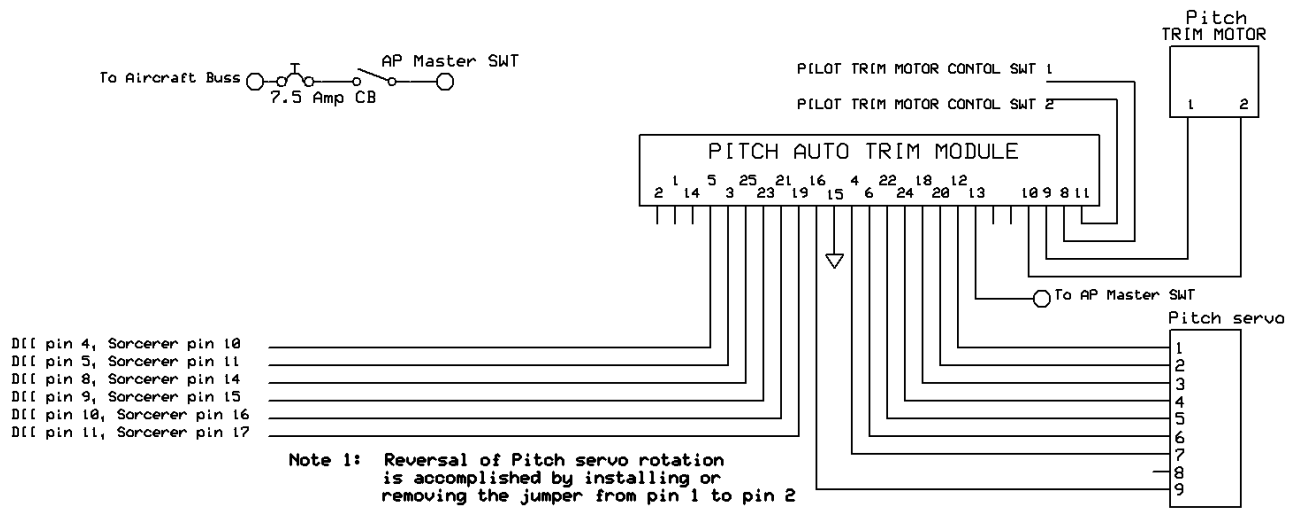

Roll Auto Trim Block Diagram

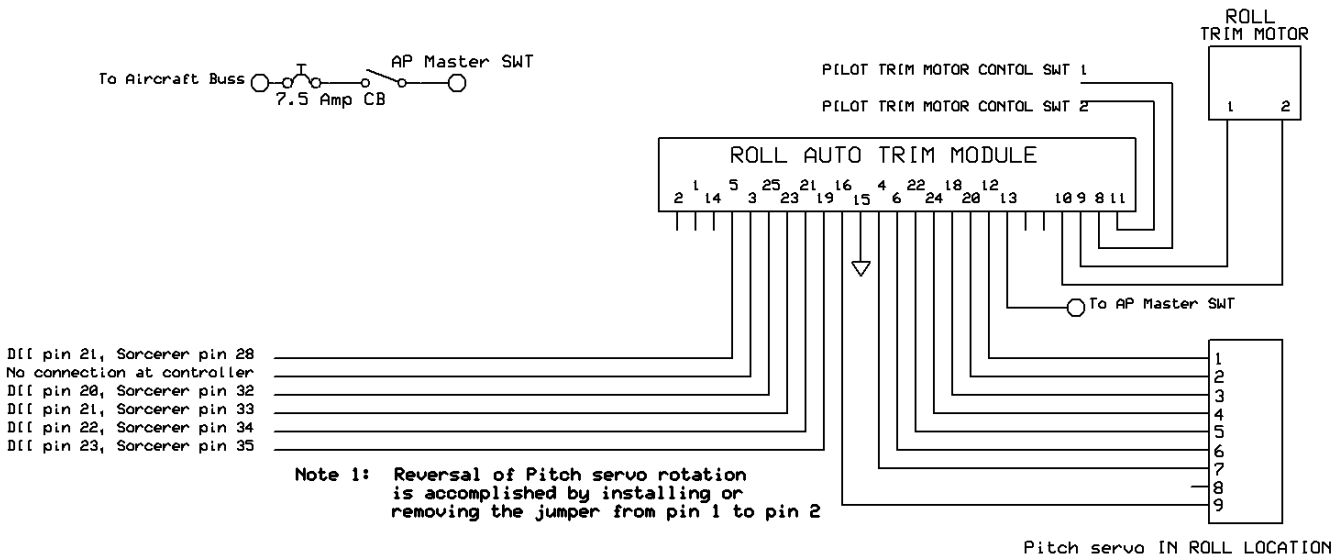

28 Volt Aircraft with 12 Volt Trim System

The Voltage that is supplied to the Auto Trim system will drive the trim motor with the same voltage when the Auto Trim system is in operation. The pitch servo and the auto trim system do NOT need to be supplied with the same voltage to work correctly.

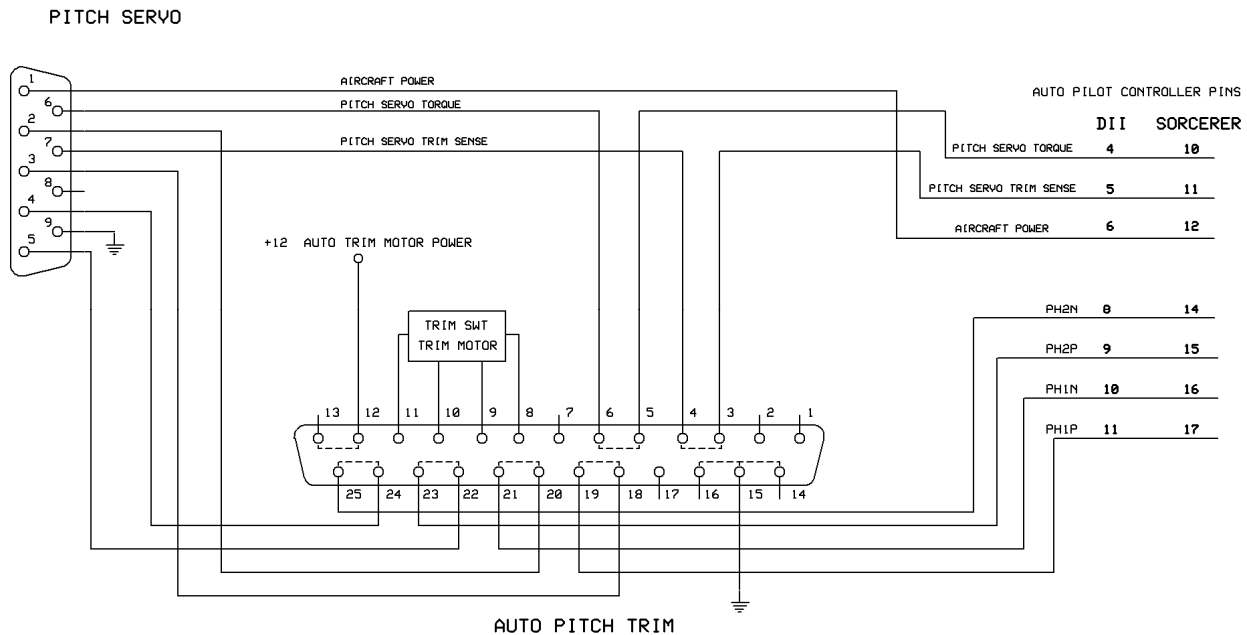

Manual Auto Trim Switching with Auto Pilot Engaged

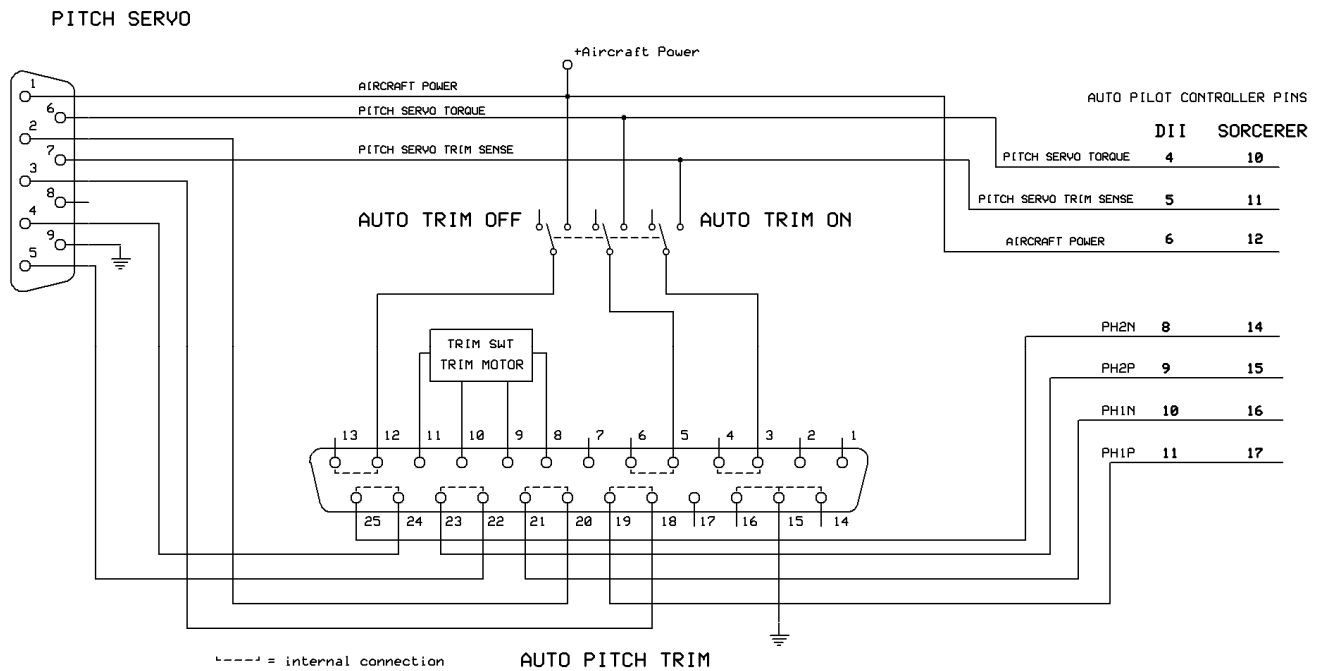

Trouble Shooting

Problem	Cause	Corrective Action
Trim motor will not move with control pressure and manual trim control is functional	No aircraft voltage and/or torque voltage to auto trim system	Correct power, ground, & torque wiring Engage auto pilot before testing
Trim motor will not move & manual trim control nonfunctional	Trim sense voltage incorrect with auto pilot engaged from pitch servo pin 7	Check 2.5 voltage at pin 3 or 4 Voltage will increase or decrease with elevator pressure
Trim motor only runs in one direction	Auto trim motor control wires not connected to trim motor (relays).	Auto trim motor control wires must be connected to the trim motor only.
Trim bar briefly shows on autopilot display	Auto trim controller speed too slow	Rotate knob on controller clockwise
Aircraft hunts up & down in pitch	Auto trim controller speed too high	Rotate knob on controller counter clockwise



RETURN MERCHANDISE POLICY AND PROCEDURE

Under no circumstances should products be returned to TruTrak without first obtaining a Return of Merchandise Authorization number (RMA #) from TruTrak. An RMA # may be obtained by contacting us at 866-878-8725.

Products that do not have an RMA # will not be processed.

Please include some form of documentation stating the reason for the return and describing any symptoms, failure modes, suspected causes of damage, diagnostics performed, data collected, etc.

Product(s) should be packaged in their original shipping containers. In lieu of this, they should be very carefully packaged in containers suitable to protect them during transit. Note that damage caused during shipping will not be repaired under warranty.

The outside of the box must be clearly marked with the RMA # issued by TruTrak and the RMA # must also be noted on the return documents.

Products will be returned to the customer at no charge via FedEx Ground or UPS Ground. If customer requests expedited shipping (2nd Day or Overnight) they will be charged the shipping cost and must supply a credit card number.

Send ALL return shipments to:

Trutrak Flight Systems, Inc.
1500 South Old Missouri Road
Springdale, AR 72764
USA
Attention: Returns Dept.
RMA# _____

Warranty On TruTrak Flight Systems Products

We here at TruTrak Flight Systems know how important it is to feel as though the customer is purchasing a product that the manufacturer is going to stand behind. For this reason we want offer more than the basic one year warranty that is standard to this industry. The warranty on all TruTrak products will be three years from the date of purchase. Abuse and misuse of a product are not covered under this warranty. Modification to a product may void the warranty, as well as carry a penalty when upgrading to another product. This three year warranty will be for all products except the Pictorial Turn & Bank, which will continue to have a warranty of one year from the date of purchase.

TruTrak Flight Systems No Penalty Upgrade Policy

As the product line continues to grow, it becomes increasingly difficult to maintain a simple upgrade policy. We do want to reward our repeat customers by allowing a lower cost upgrade from one system to another; however we are not able to offer this across the board on all products. If you are considering an upgrade, please call and we will give you a quote on what this would cost. Many products that we sell today are upgradeable for only the difference in system price. Because we continually strive to have the most up to date products possible, we occasionally have to discontinue products. We will continue to offer discounted upgrades even for our discontinued products.

THIS PAGE UNINTENTIONAL LEFT BLANK

TRUTRAK FLIGHT SYSTEMS

1500 S. Old Missouri Road

Springdale, AR 72764

Ph: 479-751-0250 Fax: 479-751-3397

Toll free: 866-TRUTRAK

866-(878-8725)

www.trutrakap.com