

PROBLEMS WITH EUROPA XS 912ULS INTAKE WATER INTRUSION  
A problem posed by Bud Yerly

As many of you know, I install very few 912ULS engines as I believe that the 914 is the ideal engine for the Europa XS. That said, for the pilot not interested in flying high and fast but a little lower, with lower up front costs and fewer maintenance headaches, the 912UL and 912ULS are very acceptable substitutes. Particularly the 912ULS of 100 HP when equipped with a constant speed propeller. It is only slightly slower in cruise, lighter, has excellent takeoff performance when operating at density altitudes of less than 3000 feet, and is reasonable at cruising altitudes of 7000 feet or below. Granted it has been eclipsed by the new 912iS engine, but it is still much more cost effective than the newest Rotax injected computer babies and can be maintained with simple hand tools.

I recently had a second hand owner of a nicely built Europa XS powered by a 912ULS, which was built in accordance with the Europa manual, have to store his aircraft outside on the airport ramp for a year in central Florida. Time passed as he was busy with debilitating medical difficulties. I saw the aircraft derelict and looking like a mildew experiment. I decided to do some checking. I last saw the aircraft around Christmas time, however, we've had some 30 inches of rainfall and extremely warm weather since then.

I received the OK from the owner and airport and on initial inspection, I could not pull the prop through. I opened up the cowl, and found the #1 and 3 cylinders had water in them, the airbox had some black mildew on the starboard side which plugged the 1/8 inch drain hole completely. This resulted in the starboard carb float bowl filling with water. The entire 1/3 carb had a redish brown film. The redish brown film was a fungus common here in Florida which grows on the inside surface of fuel tanks in the steamy summers. Further inspection showed the intake manifold slime covered also. The owner agreed to allow me to transport the aircraft back to the shop to dry it out and perform an engine and airframe condition inspection. After washing the exterior, upsetting many insect colonies, removing the carbs, pulling the plugs and lower oil return line, I removed a half cup of water from the cylinders and about the same from the bottom of the crank case. Luckily, the water in the crankcase simply flowed to the bottom and was covered by the settled oil. The bore scope revealed the pistons valves rings and cylinder walls were remarkably clean. His gearbox on removal showed no sign of water intrusion and looked like new. He got lucky.

I am now looking into what can correct this from happening to others with stock installations. Many of you owners have had similar comments over the years about the NACA duct opening on the 912ULS allowing water to flow into the intake box. For short time outside tie down, the drain holes of 1/8 inch should be fine to drain most of the water that could possibly seep in. But to prevent water intrusion totally when tied down, the solutions were many and varied. For some builders you simply:

1. Never leave your aircraft outside in the rain. Obvious, but not always possible.
2. Cover the aircraft with a rain proof cover when tied down. Obvious for lengthy tie downs. However, for the average cross country flight, these covers can be quite bulky. The Europa does not have a sail locker in the bow. The covers are a bit pricey also.
3. A plug can be devised to block the inlet and most of the water. An inexpensive fix if done right.
4. Tape over the hole for tie down.
5. Fabricate a 914 style inlet and ducting to avoid the NACA rain inlet problem completely.

For the diligent builder who follows the instruction without modification or the second hand owner who must tie his aircraft down in a rainstorm, is there a solution other than plugs and tape that can be easily done during an annual condition inspection to relieve him of the fear of a waterlogged engine?

I will provide some construction background and diagrams on why this is an issue and perhaps some ideas of my own below, but I am interested in your solutions also.

Custom Flight Solutions to the Europa XS inlet water injection:

Europa XS engine installation fabricates an inlet and airbox as follows:

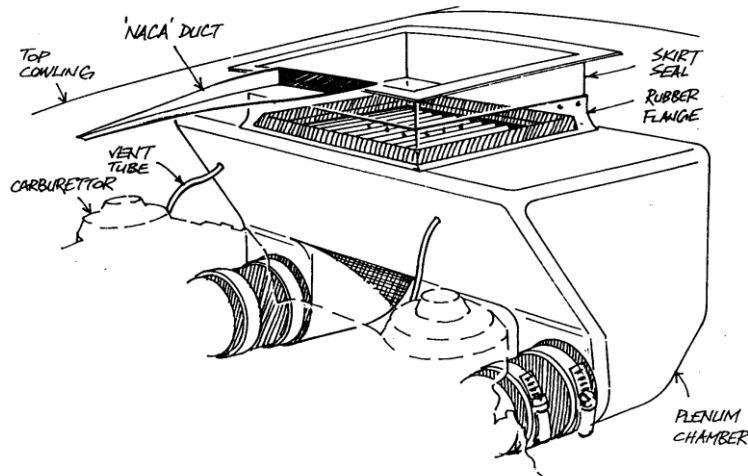

The builder uses a template to mold the NACA duct inlet. Since each cowl is slightly different in length due mainly to the spinner of choice, this NACA duct inlet can be actually over the air filter element. The Mono Wheel Europa is especially problematic as the slope of the NACA and nose high attitude is a perfect funnel for rain intrusion. Most of us follow the installation manual and don't notice that the drawing is somewhat misleading in that the end of the NACA duct inlet doesn't always fall well forward of the filter hole as shown in the manuals drawing below.

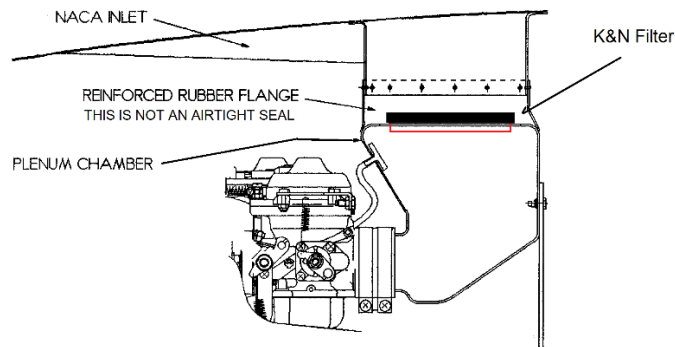

In many cases it looks more like this drawing:

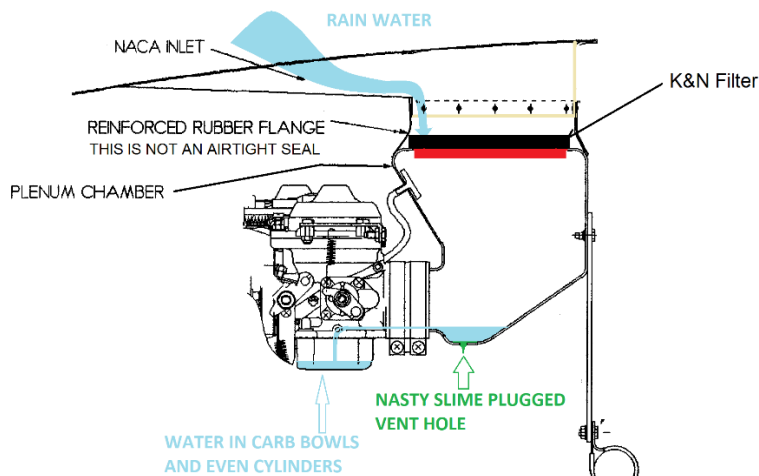

Some solutions I have done I don't recommend as they are bulky and time consuming to build, but work flawlessly. Below is a 912ULS with a 914 cowl inlet and airbox on the starboard side. We fabricated a large snorkel to move the air to the box on the firewall which contains a filter. The carbs are fed by red SCEET tubing making a clean inflow to the carbs. This is uncomfortably tight so provisions were made to allow for quick removal to facilitate other maintenance.

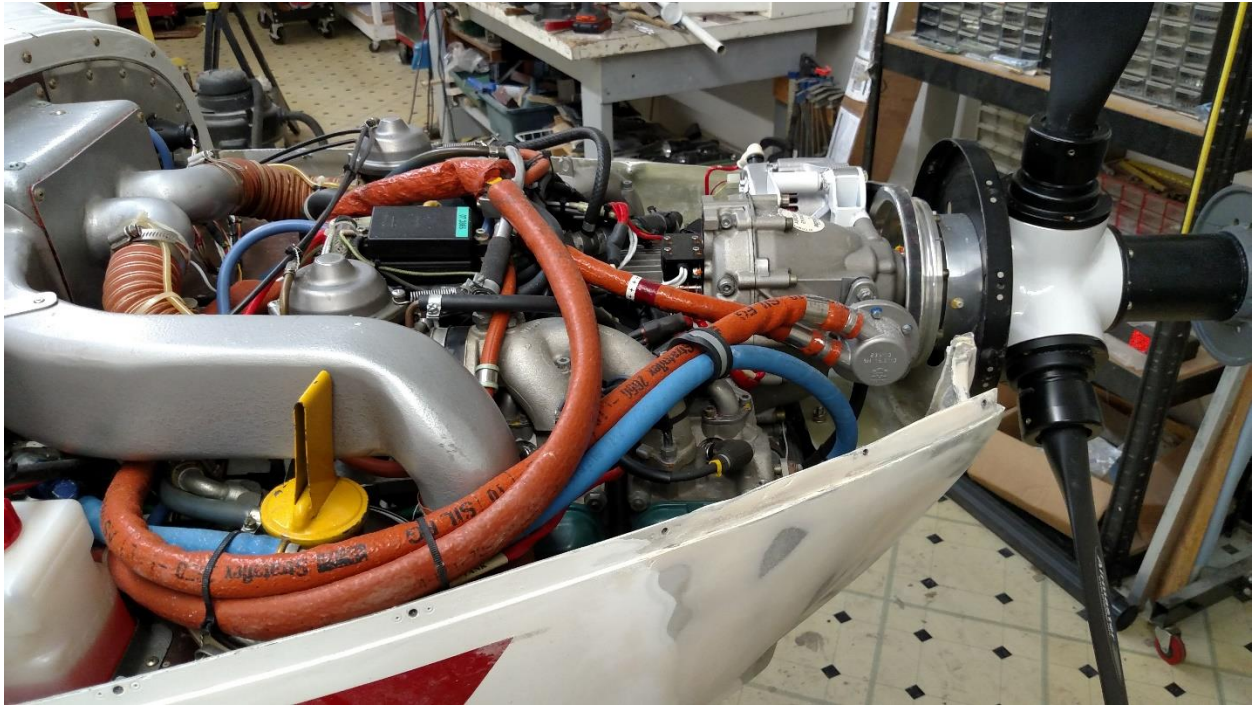

Another modification was to install the filter well aft of the NACA inlet with a raised filter dam to prevent water running from the NACA inlet lip into the filter. The filter was a Fram 3144 which is slightly smaller than the Europa K&N CA4309. This was not easy to do, but it made for a dry airbox when a pitcher of water was dumped into the NACA on a trigear. The whole setup was to install a hot air carb heat. Unfortunately, this setup never saw service as the engine was swapped for a 914 by a new owner.

1. Use a standard ACS heater box set in a foam box then glassed over.

To fab, make the box and the inlets to the carbs first. Glass the box and remove the foam. Install the heater box then the filter holder.

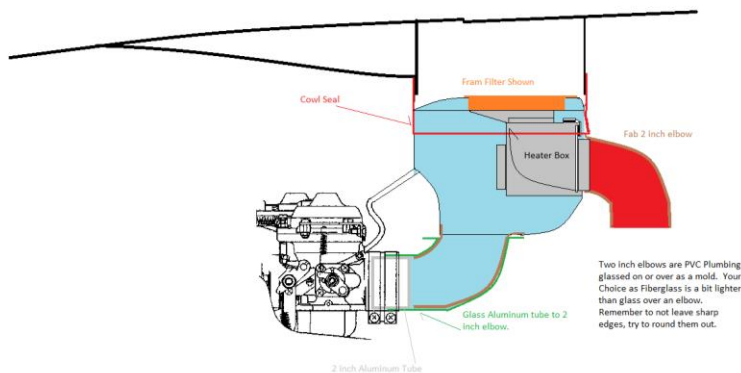

There are solutions but perhaps a simple fiberglass deflector may be all that is needed. A slightly curvy piece of glass installed into the cowl top to simply channel the water away from the filter. The glass could be fabricated in place and use cowl seal and fiberglass to make a water channel.

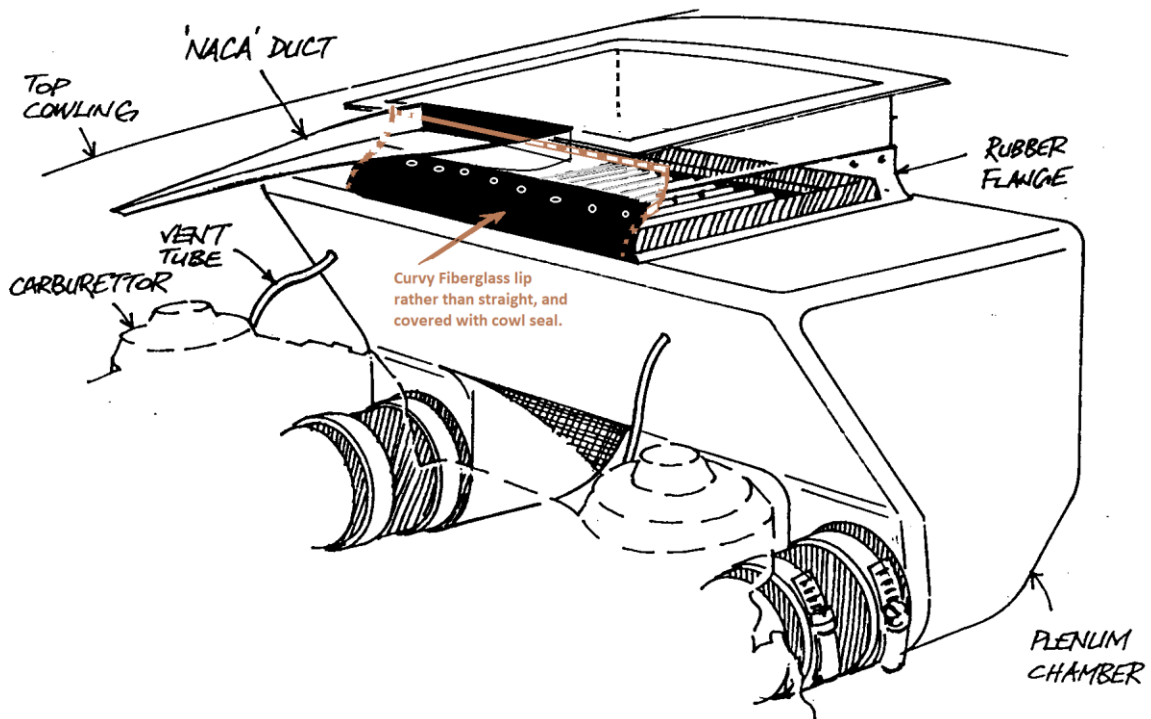
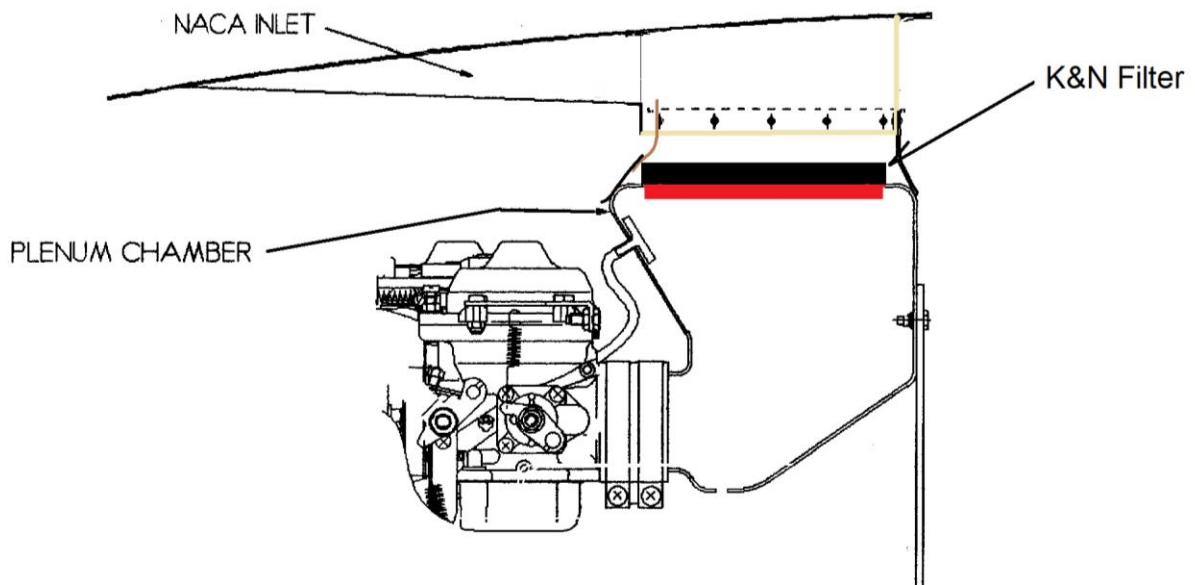

The above worked extremely well on simulated rain testing and only took a few hours to fabricate, rivet and cowl up final. Give it a thought.