

Custom Flight Creations Europa Throttle Friction and Idle and 100% Stop Modification

By Bud Yerly

I am always amazed at how inconvenient the throttle is in the Europa. I prefer a throttle lever to a knob, and I am disgusted with the products available in the after-market which could work in the Europa, but don't always. I decided to do something about it. I needed easily adjustable stops, a friction knob or lever, and a 100% detent to allow full continuous power, as the Rotax 914 installation manual describes, that allows climb power without initial reference to my manifold gauge, especially while in the pattern practicing or while flying instrument approaches.



Photo of N12AY throttle friction lever installation.

To be honest, as a pilot, I have flown nearly all my life with a throttle friction which was cockpit adjustable and easy to use. I could set the friction for ease of movement in formation flying, or firm for cruising to prevent throttle creep.

In light aircraft, the idle stop was always needing setting for winter, summer and spring/fall or after prop angle setting. In my experience, if I set my prop a little more coarse for cruise or fine for takeoff, I had to be able to adjust the ground idle also or the engine was idling too fast or too slow. I also found, especially with a fixed pitch prop set for cruise, I could adjust the idle a bit lower to allow for a slower in flight idle on final for those short field landings. To achieve a simple cockpit adjustable idle, it had to be cockpit adjustable without disassembly of the cockpit to get at the throttle quadrant or by replacing/drilling or filing on a tab.

The Rotax 914 is a wonderful engine, but again, has some complex and wonderful fiddly things one must do to meet their operational requirements. In the Rotax engine installation manual, it clearly requires an adjustable stop for idle and a 100% throttle (5500 RPM at 34-35 inches of manifold pressure) to hold the throttle out of the "5 minute zone" of the 104-115% full boost area. I found compliance with this to be terribly easy using the Europa supplied throttle box and arm. Even an adjustable idle stop was easy.

First the 100% stop position. From the Rotax 914 installation manual:

BRP-Rotax
INSTALLATION MANUAL

15.4) Requirements on the throttle lever

See fig. 39.

From throttle position 108 to 110 % the boost pressure rises rapidly and the throttle becomes very sensitive in this range. Therefore try to prevent operation in this small range or if setting for take-off performance pass this range quickly.

Consult also the chapter "electric system" for the description of the system.

For this reason it is recommended to assist the pilot with an visual/manual arrangement at setting for max. cruise performance.

A detent on your throttle lever at max. continuous power would be most suitable. Provide this detent at throttle position 104% corresponding to 8-9 mm (5/16" - 11/32") travel before full throttle stop.

The sketch (fig. 39) depicts a feasible arrangement.

The throttle lever is pressed onto throttle gate and comes to a stop at max. continuous power. Against the spring force the throttle lever will be released from the detent and can be moved further to take-off performance.

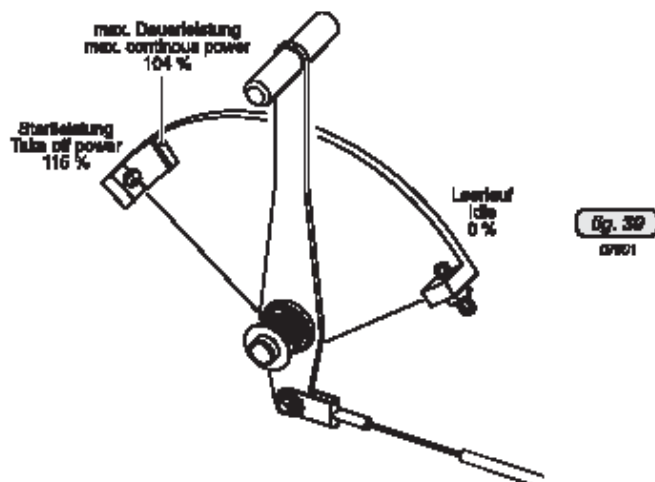

- **CAUTION:** Adjustable positive stops for idle- and full throttle position are of course required.
These stops have to be designed such to render adjustability and to prevent overload of the Idle stop on the carburetor.

Obviously they have only one cable showing, so a splitter or two cables must be used also.

The detent for the 100% stop is just a piece of aluminum angle of 1 inch by 1/16 wall, shaped to just fit in the throttle box. The tip of the inner top angle is slanted and shaped to fit half way into the throttle slot so as to just hit the throttle lever sufficiently to stop forward movement and only require a slight bit of pressure starboard to move the throttle past the stop and continue forward to full boost or 115% throttle. See drawing below.

Rotax 914 throttle detent and stop detail for ease of operation.

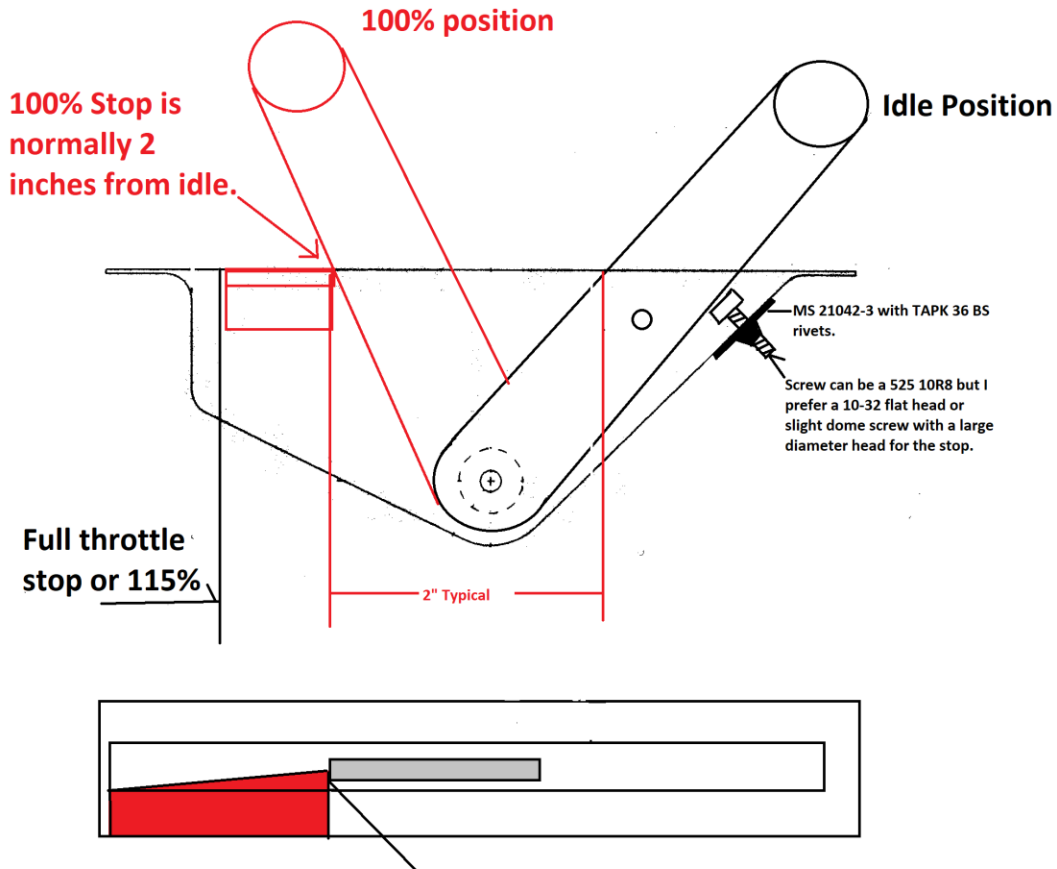

Note: 100% Throttle detent is far enough into the slot to catch the throttle, and give the feel of a stop, however, it is positioned so as to allow a slight outward bend of the throttle to achieve full 115% position required for full turbo boost position.

I found that setting my throttle using the Rotax dongle at 100% was the most accurate means of positioning the detent exactly, but it was soon found that the Europa throttle arm and the Rotax Bing carburetor handle were roughly the same dimensions. I found that setting the throttle at idle, then measuring two (2) inches forward of that point on the leading edge of the throttle was about right. I install the angle and use a cleco to hold it firm and place the detent where I want it, then clamp and drill

the second hole is for a final fix. You can fine tune the stop with the engine running, provided you can remove your throttle box and hold it in your hand to set it is convenient. I prefer not to, for obvious reasons. Normally it is safe to push up the throttle to max continuous, make a mark on your throttle box, then fit the stop. Now for the friction.

For the idle stop, instead of a tab to file on, I decided to install a nut plate and screw in the rear of a typical throttle box. Easy and cheap. However, the type of screw became a problem. The throttle stop screw head had to be wide enough for an acceptable stop, and easy to slide a Phillips screwdriver into the slot gap was important also. I normally use a #10-32 all thread Phillips head with a flat top. Why a flatish top was necessary was the screw head is a bit wider and when centered you can't bend the throttle enough to bypass the stop, however a AN 525 will work as well as a flat topped screw.

Since friction is controlled by a MS 21042-4, 1/4-28 nut, in the existing Europa throttle box, one must use two or three wrenches to adjust the throttle friction. I said to myself, "Self, why not use a K1000-4 nut plate on an aluminum handle that sticks out the top of the throttle box to adjust the friction." It could be built on the bench, tested and installed by simply filing out a notch for the adjustment handle in your throttle cover as seen in my N12AY. The problem was the 1/4 - 28 all thread bolt, called the Euro 23, will spin while moving the adjustment handle unless overly tightened, glued or fixed. So, a means of fixing the Euro 23 was necessary. I chose to cross drill the head of the Euro 23 and the AN 970-4 washers and use safety wire to secure the bolt. To secure the bolt, I looped wire through the two AN 970-4 washers I match drilled and wired the drilled bolt head to prevent rotation. Another method is to use two small screws to lock the head. I like the latest auto bolt head locking techniques by Stage 8 and ARP can also be used but you must have a special bolt. Drilling the head of the Euro 23 bolt and safety wire is the cheapest still.

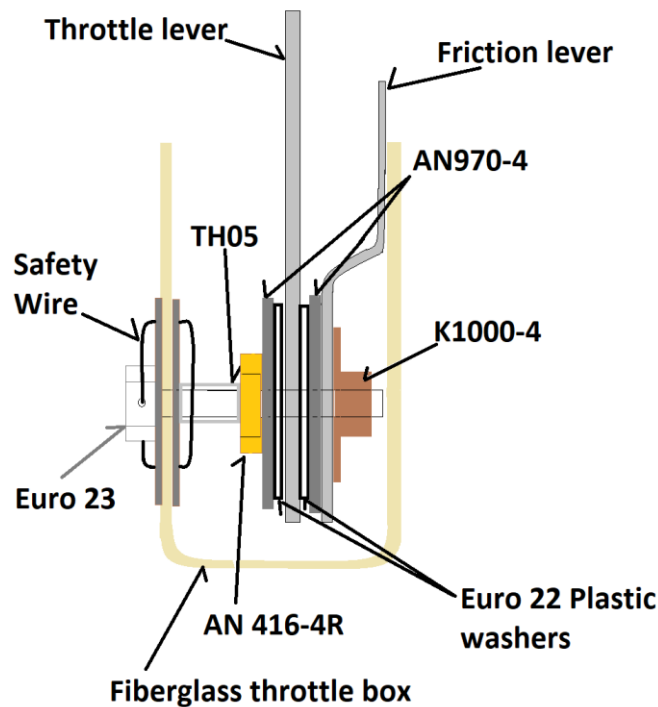

The throttle friction lever installation is quite easy as the drawing below indicates. Keep in mind that the threaded bolt and stop nut must be loosened to get the friction lever started then after all is set, and throttle friction lever movement is just right, then secure the bolt from spinning via safety wire.

Custom Flight Throttle Friction Mod for the Rotax 914

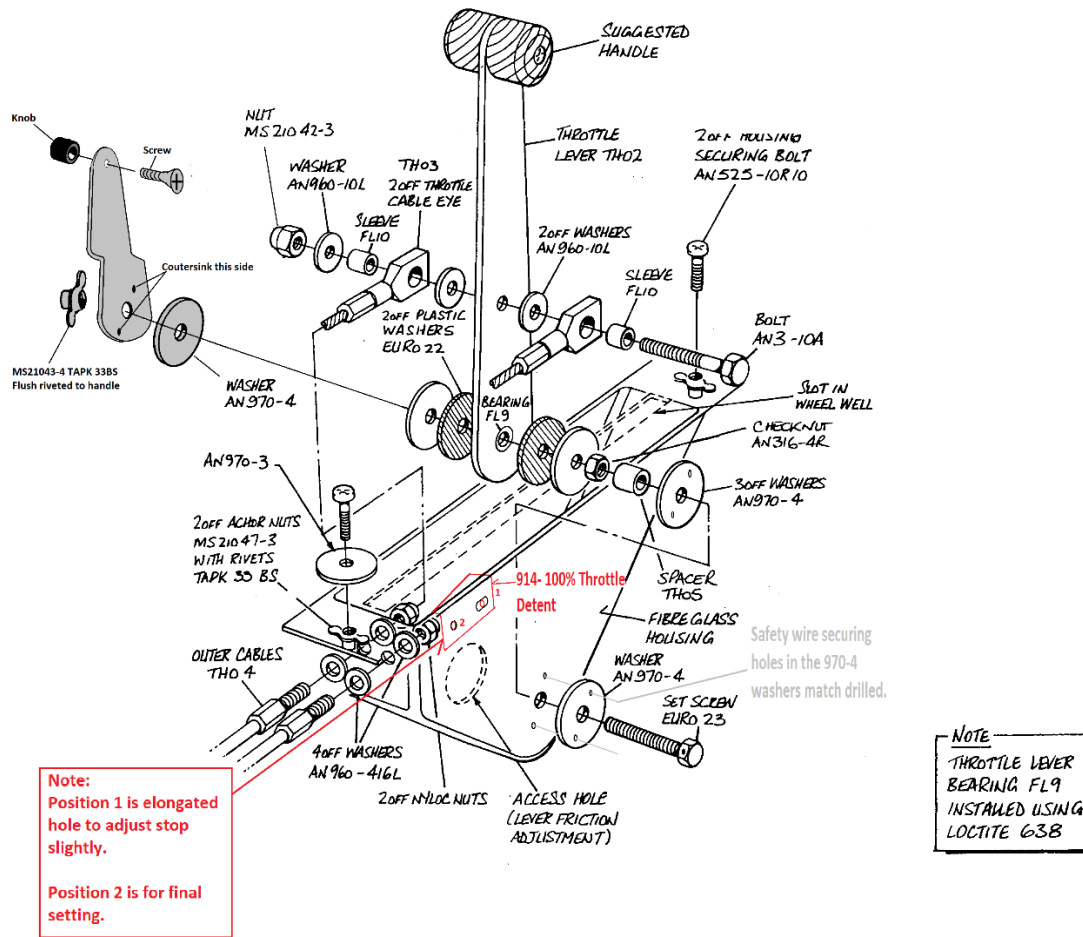

So let your imagination run wild. There are many ways to secure a Euro 23 or threaded rod. The only thing that matters is to prevent the bolt from rotating in either direction as the friction lever can put quite a bit of torque on the Euro 23. I have also added another plastic ¼ inch nylon washer between the friction handle and the 970-4 for better operation and additional 970-4s to adjust the spacing between the two levers to prevent interference. Note that the friction lever must be either spaced or bent to ensure the friction lever will clear the AN3 bolt holding the cable ends. I prefer to use a combination of washers and a slight bend in the friction handle to get just the right clearance.

On your next annual, or if you are having cable issues (that is a different story), try cockpit adjustable throttle friction.