

Rotax/Ducati R/R proposed principle of operation (JdJ 2017)

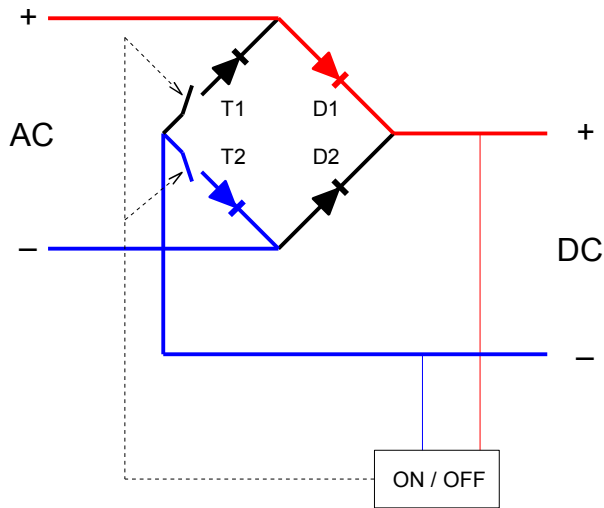

AC half cycle 1 of 2  
thyristors ON if DC voltage below setpoint  
→ current through thyristor 2 and diode 1  
thyristors OFF otherwise  
→ no current

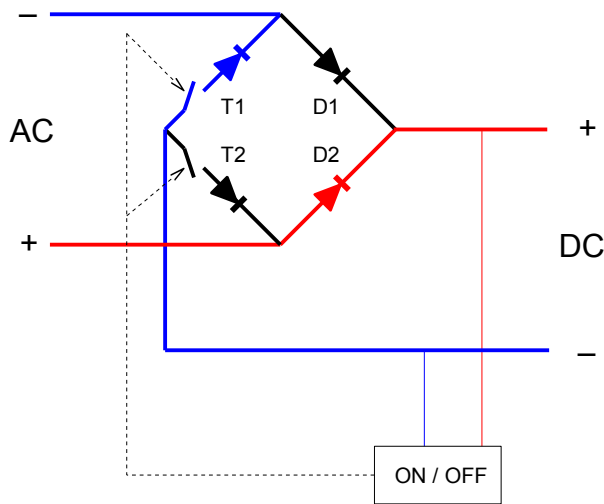

AC half cycle 2 of 2  
thyristors ON if DC voltage below setpoint  
→ current through thyristor 1 and diode 2  
thyristors OFF otherwise  
→ no current

remarks:

- the negative DC terminal is connected to aircraft ground
- a capacitor across the DC terminals supports DC voltage when no current flows