

Apollo[®]
Mode A/C Transponder
Model SL70R
Installation Manual

April 2003
560-0408-01

UPS Aviation Technologies



©2003 by UPS Aviation Technologies Inc. All rights reserved.
Printed in the USA

No part of this document may be transmitted, reproduced, or copied in any form or by any means without the prior written consent of UPS Aviation Technologies Inc. Due to UPS Aviation Technologies' commitment to constantly improve the quality and performance of our products, information contained in this document is subject to change without notice.

UPS Aviation Technologies, Apollo, and FlyBrary are registered trademarks of UPS Aviation Technologies, Inc.

UPS Aviation Technologies Inc.
PO Box 13549
Salem, OR 97309

2345 Turner Rd. SE
Salem, OR 97302
USA

Phone: 503.581.8101
Toll Free: 800.525.6726
In Canada: 800.654.3415
Fax: 503.364.2138

HISTORY OF REVISIONS

Revision	Date	Description
--		Initial release.
-01	4/7/03	Added TSO requirements to Environmental Qualification Form. Added to Serial Specification section.

IMPORTANT NOTE

“The conditions and tests required for TSO approval of this article are minimum performance standards. It is the responsibility of those desiring to install this article on or within a specific type or class of aircraft to determine that the aircraft operating conditions are within TSO standards. The article may be installed only if further evaluation by the applicant documents an acceptable installation and is approved by the Administrator.”

Source: TSO-C74c

ORDERING INFORMATION

To receive additional copies of this publication, order part # **560-0408-xx**, *Apollo SL70R Mode A/C Transponder Installation Manual*.

REFERENCE PUBLICATIONS

NOTES

TABLE OF CONTENTS

1. GENERAL INFORMATION	1
1.1 ABOUT THIS MANUAL	1
1.2 APOLLO SL70R DESCRIPTION.....	1
1.2.1 GENERAL FEATURES.....	1
1.2.2 SYSTEM INTERFACES	2
1.2.3 HOST FAILURE	2
1.3 SPECIFICATIONS	2
1.3.1 ELECTRICAL.....	2
1.3.2 PHYSICAL (AS VIEWED INSTALLED)	2
1.3.3 ENVIRONMENTAL.....	3
1.4 ALTITUDE INPUT	3
1.5 DISCRETE INPUTS.....	3
1.6 SERIAL INTERFACE.....	3
1.7 TRANSPONDER PERFORMANCE.....	3
1.8 REGULATORY COMPLIANCE	4
1.9 UNPACKING THE EQUIPMENT	4
1.10 PACKAGE CONTENTS	4
2. INSTALLATION PROCEDURES.....	7
2.1 PRE-INSTALLATION INFORMATION.....	7
2.2 INSTALLATION OVERVIEW	7
2.3 OTHER REQUIRED MATERIALS.....	7
2.4 SPECIAL TOOLS REQUIRED.....	7
2.5 INSTALLATION CONSIDERATIONS.....	8
2.5.1 MINIMUM SYSTEM CONFIGURATION.....	8
2.5.2 MOUNTING CONSIDERATIONS.....	8
2.5.3 CABLING AND WIRING.....	8
2.5.4 AIR CIRCULATION AND COOLING	8
2.6 EQUIPMENT MOUNTING	8
2.6.1 UNIT INSTALLATION/REMOVAL.....	9
2.7 ELECTRICAL CONNECTIONS	9
2.7.1 INTERFACE CONNECTOR DEFINITION.....	11
2.8 ANTENNA INSTALLATION AND CONNECTIONS	12
3. POST INSTALLATION AND CONFIGURATION PROCEDURES.....	17
3.1 MOUNTING / WIRING CHECK	17
3.2 EQUIPMENT SETUP AND CONFIGURATION	17
3.2.1 ALTITUDE INPUT SOURCE SELECTION.....	17
3.2.2 RS-232 BAUD RATE SELECTION.....	17
3.3 EQUIPMENT OPERATIONAL/FUNCTIONAL TEST.....	17
3.3.1 SELF TEST.....	17
4. TROUBLESHOOTING	21
4.1 TROUBLESHOOTING PROCEDURE	21
4.2 CONTACTING THE FACTORY FOR ASSISTANCE	22
5. LIMITATIONS	25
5.1 INSTALLATION	25

5.2	OPERATIONAL	25
6.	PERIODIC MAINTENANCE	27
6.1	BIENNIAL CHECK	27
7.	SERIAL INTERFACE SPECIFICATION.....	29
7.1	INTRODUCTION.....	29
7.2	GENERAL REQUIREMENTS.....	29
7.2.1	HOST INTERFACE	29
7.2.2	HARDWARE INTERFACE	29
7.2.3	BAUD RATE	29
7.2.4	COMMUNICATIONS.....	29
7.2.5	MESSAGE DEFINITIONS	29
7.3	OUTPUT MESSAGES.....	30
7.3.1	ALTITUDE	30
7.3.2	MODE MESSAGE	31
7.3.3	REPLY COUNT.....	32
7.3.4	INTERFACE SPECIFICATION	32
7.3.5	CONFIGURATION MESSAGE.....	32
7.3.6	SYSTEM STATUS	33
7.4	INPUT MESSAGES	34
7.4.1	ALTITUDE	34
7.4.2	MODE	35
7.4.3	SOFTWARE VERSION.....	36
7.4.4	RESET	36
7.4.5	SET OPERATION	36
7.5	SETUP MODE MESSAGE DEFINITIONS	37
7.5.1	OUTPUT MESSAGES	37
7.5.2	EEPROM DATA	37
7.5.3	INPUT MESSAGES.....	38
7.5.4	INIT EEPROM.....	38
7.5.5	SET VFR.....	38
7.5.6	VIEW EEPROM.....	39
APPENDIX A.	ENVIRONMENTAL QUALIFICATION FORM.....	41

LIST OF TABLES

TABLE 1-1 PACKAGE CONTENTS	5
TABLE 2-1 REAR CONNECTOR PINOUT	11
TABLE 4-1. TROUBLESHOOTING GUIDE	21
TABLE 7-1. OUTPUT MESSAGES	30
TABLE 7-2. ALTITUDE MESSAGE FORMAT	30
TABLE 7-3. MODE MESSAGE FORMAT	31
TABLE 7-4. MODE TABLE	31
TABLE 7-5. IDENT TABLE	31
TABLE 7-6. REPLY COUNT MESSAGE FORMAT	32
TABLE 7-7. CONFIGURATION 1 MESSAGE FORMAT	32
TABLE 7-8. SELF-TEST BIT DEFINITION	33
TABLE 7-9. SOFTWARE VERSION MESSAGE FORMAT	33
TABLE 7-10. NORMAL MODE INPUT MESSAGES	34
TABLE 7-11. ALTITUDE MESSAGE FORMAT	34
TABLE 7-12. MODE MESSAGE FORMAT	35
TABLE 7-13. MODE TABLE	35
TABLE 7-14. IDENT TABLE	36
TABLE 7-15. SOFTWARE VERSION MESSAGE FORMAT	36
TABLE 7-16. RESET MESSAGE FORMAT	36
TABLE 7-17. P1 PULSE MESSAGE FORMAT	37
TABLE 7-18. ARGUMENTS	37
TABLE 7-19. EEPROM DATA MESSAGE FORMAT	37
TABLE 7-20. SETUP/TEST MODE OUTPUT MESSAGES	38
TABLE 7-21. INIT EEPROM MESSAGE FORMAT	38
TABLE 7-22 VFR MESSAGE FORMAT	39
TABLE 7-23 VIEW EEPROM FORMAT	39

LIST OF ILLUSTRATIONS

FIGURE 2-1. CABLE ROUTING	8
FIGURE 2-2. MOUNTING TRAY FOR SL70R	9
FIGURE 2-3. REAR VIEW OF SL70R	10
FIGURE 2-4. COAX CABLE ASSEMBLY	12
FIGURE 2-5. WIRING DIAGRAM - GRAY CODE ALTITUDE INPUT	13
FIGURE 2-6. WIRING DIAGRAM – HOST SERIAL ALTITUDE INPUT	14

NOTES

1. GENERAL INFORMATION

1.1 ABOUT THIS MANUAL

This manual describes the installation of the Apollo SL70R transponder. It is intended for use by persons certified by the Federal Aviation Administration (FAA) to install aircraft avionics.

Section 1	Provides GENERAL INFORMATION about the Apollo SL70R unit. TSO certification information is also included in this section.
Section 2	Includes INSTALLATION and checkout procedures.
Section 3	Includes complete POST-INSTALLATION AND CONFIGURATION PROCEDURES .
Section 4	Includes TROUBLESHOOTING information.
Section 5	Includes LIMITATIONS for the equipment and installation.
Section 6	Includes PERIODIC MAINTENANCE requirements.
Section 7	Includes SERIAL SPECIFICATION information.
Appendix A	Includes the ENVIRONMENTAL QUALIFICATION FORM .

1.2 APOLLO SL70R DESCRIPTION

The Apollo SL70R is an incomplete system and when connected to an appropriate host, will function as a TSO-C74c, Class A2, mode A/C transponder. The SL70R, in addition to providing replies to ATC interrogations, can provide altitude reporting, squawk code selection, and has built-in self-test and diagnostics.

1.2.1 GENERAL FEATURES

- small footprint
- remotely mounted
- full range input supply voltage
- altitude reporting
- gray code or RS-232 serial data altitude input
- RS-232 altitude data output
- built-in self-test and diagnostics
- host controlled

1.2.2 SYSTEM INTERFACES

1.2.2.1 SERIAL INTERFACE

The SL70R includes an RS-232 serial port which is used to control the transponder from a host.

When making serial connections to the SL70R, use a shielded two or three conductor cable. Make the RxD, TxD, and serial ground connections on the 37 pin D-sub connector. Connect the shield to the rear of the mounting frame on the connector plate.

1.2.3 HOST FAILURE

If the host stops sending altitude data to the SL70R, or upon power up if the SL70R does not receive data from the host, then within 60 seconds the SL70R will enter Host Failure Mode. In this mode, the SL70R will revert to altitude reporting (Mode C) using the current squawk code. If the power is cycled the squawk code will revert to the default VFR squawk code.

If the SL70R is configured for gray code altitude input, the transponder will continue to transmit altitude data. If the SL70R receives altitude data from the host, in the event of host failure, no altitude data will be transmitted.

If the host resumes normal operation, the SL70R then reports Mode C operation to the host and altitude reporting resumes if valid serial data is supplied from the host.

1.3 SPECIFICATIONS

This section includes detailed electrical, physical, environmental, and performance specifications for the Apollo SL70R.

1.3.1 ELECTRICAL

Input voltage	10VDC to 35VDC, reverse polarity protected
Input current.....	500mA typical, 1.4A max at 14VDC 270mA typical, 660mA max at 28VDC
Input power	7 watts typical (8 pulse reply, 200 replies / second) 20 watts max (12 pulse reply, 1200 replies / second) 5.8 watts standby
Internal fuse.....	3 amp slow blow (UPS Aviation Technologies #S172-0007-012)
Memory backup	Internal EEPROM

1.3.2 PHYSICAL (AS VIEWED INSTALLED)

Width.....	1.30 inches (3.30 cm)
Height.....	6.875 inches (15.88 cm)
Depth.....	11.452 inches (29.09cm)
Weight (with mounting frame).....	2.2 lb. (0.998 kg)

Required clearance..... Allow one inch behind unit for connector and cable clearance

1.3.3 ENVIRONMENTAL

The Apollo SL70R is designed and tested to meet appropriate categories of RTCA/DO-160D. The Environmental Qualification Form is included in Appendix A.

Operating temperature..... -20°C to +55°C
 Storage temperature -55°C to +85°C
 Temperature variation 2°C per minute
 Humidity 95% at 50°C for 6 hours (2 day cycle)
 Maximum altitude 25,000 feet
 Cooling..... Not required

1.4 ALTITUDE INPUT

10 bit gray code..... Uses 10 bit gray code altitude data, includes isolation diodes.
 Range: -1000feet to 63,000 feet
 On: <= 3.5 volts, Off: open

Serial input Host may supply altitude data
 (See Section 7 – Serial Interface Specifications)

Note: The altitude data input type must be selected. See Table 2-1, pin 36.

1.5 DISCRETE INPUTS

Remote Ident Input pulled low momentarily to initiate ident transmission (same function as front panel button)
 On: <= 3.5 volts, Off: open

Standby input Input pulled low to disable the transponder (will not generate replies)
 On: <= 3.5 volts, Off: open

Suppression input..... Input pulled high to initiate suppression – typically connected to DME suppression output
 Suppressed: >= 5.0 volts;
 Not suppressed: < 2.5 volts (or open)

1.6 SERIAL INTERFACE

RS-232 Defined in Section 7 – Serial Interface Specifications

1.7 TRANSPONDER PERFORMANCE

TSO TSO-C74c
 TSO Class 2A

Warm-up	none required
Receiver Frequency.....	1030 MHz
Sensitivity (MTL)	-72 dBm
Dynamic Range.....	> 50 dB
Side Lobe Suppression.....	2 pulse (P1,P2)
Transmitter Frequency	1090 MHz +/- 120 kHz
Transmitter Power.....	250 watts minimum, 325 watts typical
Reply rate	1200 / second
Mode A Capability.....	4096 codes plus SPI ident pulse
Mode C Capability	-1000 to 63,000 feet, 100 foot increments, from either gray code or RS-232 serial inputs

1.8 REGULATORY COMPLIANCE

The Apollo SL70R is designed and tested to meet the following TSO:

- FAA TSO-C74c, Class A2

The SL70R complies with the FCC requirements specified in:

- CFR 47, Part 87, Aviation Services, Subpart D, Technical Requirements

The SL70R software is designed and tested to RTCA/DO-178B, level C.

Note: Unauthorized changes or modifications to the SL70R may void the compliance to regulatory agency requirements and authorization for continued equipment usage.

1.9 UNPACKING THE EQUIPMENT

Carefully unpack the equipment. Visually inspect the package contents for any evidence of shipping damage. Retain all shipping containers and packaging material in case re-shipment is necessary.

1.10 PACKAGE CONTENTS

As shipped from the UPS Aviation Technologies factory, the Apollo SL70R package includes most necessary items for installation other than supplies normally available at the installation shop, such as wire and coax cable, the antenna, or any optional switches. The items included in the package are listed in

Table 1-1.

Table 1-1 Package Contents		
Part #	Description	Qty
430-6067-1XX	Apollo SL70R Transponder	1
424-0311-000	Apollo SL70R Installation Kit	1
162-1577	37 pin D-sub connector shell	1
162-0043	Right angle coax plug	1
202-0001	Cable tie	2
204-0037	Edge grommet	6"
221-0400	4-40 x ¼ SS pan head Phillips machine screw with lock washer	10
224-0404	4-40 x ¼ flat head Phillips machine screw	2
240-0008	9/16 OD flat washer	1
245-0027	Crimp contact for D-sub, 20 to 24 awg wire	30
265-0007	7/16" retaining ring	1
310-2506-00	Mounting Frame	1
560-0408-xx	SL70R Installation Manual – Latest Revision	1

NOTES

2. INSTALLATION PROCEDURES

This section describes the installation of the Apollo SL70R including mounting, wiring, and connections. A post installation check-out procedure is included in Section 3.

2.1 PRE-INSTALLATION INFORMATION

Always follow good avionics installation practices per FAA Advisory Circulars AC 43.13-1B, 43.13-2A, or current FAA guidance.

Follow the installation procedure in this section as it is presented for a successful installation. Read the entire section before beginning the procedure. Perform the post installation check-out before closing the work area in case problems occur.

2.2 INSTALLATION OVERVIEW

A successful installation should start with careful planning including determination of mounting location for the SL70R, antenna location and mounting, connections to an altitude data source, power, cable routing, and other required modifications.

Once the mounting location has been determined, prepare the mounting frame for installation. It may be easier to complete the wiring harness and attach the connectors to the mounting frame prior to installing the mounting frame in the aircraft.

2.3 OTHER REQUIRED MATERIALS

In addition to the materials supplied with the SL70R, the following is required.

- a suitable 2A circuit breaker which the pilot can pull out or disengage must be used. NOTE: Alternatively, a switch that is within pilot's reach may be used in conjunction with a circuit breaker.
- an altitude data source – either gray code or RS232 (host supplied data)
- a standard transponder antenna

2.4 SPECIAL TOOLS REQUIRED

Crimp Tool

A crimp tool meeting MIL specification M22520/1-01 and a positioner/locator are required to ensure consistent, reliable crimp contact connections for the rear 15 pin connector. These tools are available from:

For pin P/N 245-0027:

ITT Cannon
1851 E. Deere Ave.
Santa Ana, CA 92705-6500

Phone: 714.261.5300
Fax: 714.575.8324

Insertion tool:	ITT part #274-7006-000 (Desc. CIET-20HD)
Regular-duty Crimp tool:	ITT part #995-0001-585 (Desc. M22520/1-01)
Regular-duty Locator tool:	ITT part #995-0001-244 (Desc. TH25)
Heavy-duty Crimp tool:	ITT part #995-0001-584 (Desc. M22520/2-01)
Heavy-duty Locator tool:	ITT part #995-0001-604 (Desc. M22520/2-08)

2.5 INSTALLATION CONSIDERATIONS

2.5.1 MINIMUM SYSTEM CONFIGURATION

The SL70R requires connections to the following equipment as a minimum:

- power input
- connection to host system
- altitude data – gray code or host supplied serial data
- a standard transponder antenna

2.5.2 MOUNTING CONSIDERATIONS

The SL70R is designed to mount in the avionics bay in the aircraft. The standard package includes the mounting frame for ease of mounting, connections, and service of the unit. Allow sufficient clearance to route cables.

2.5.3 CABLING AND WIRING

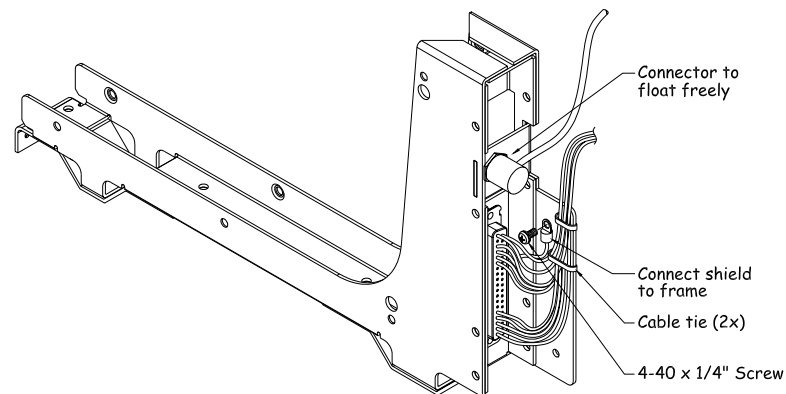

Note: The length of cable used for the serial connection between the SL70R and the host should not exceed 20 feet.

Figure 2-1. Cable Routing

2.5.4 AIR CIRCULATION AND COOLING

For typical installations, the SL70R does not require external cooling.

2.6 EQUIPMENT MOUNTING

Once the cable assemblies have been made, attach the 37-pin D-sub and coaxial cable connectors to the rear connector mounting plate and the mounting frame. Route the wiring bundle as appropriate. The rear connector plate should be attached to the mounting frame before installing. The rear connector plate can be used to tie down the cable assemblies. Connect the shields on any shielded cables directly to the connector mounting plate.

Once the cable assemblies are complete and the connectors are attached to the mounting frame, install the mounting frame assembly in the aircraft.

The following recommendations are made for fastening the mounting tray to the aircraft. Note the requirement for some means of locking the fasteners.

Fastener Size: # 8 x 32

Fastener Tensile Strength: 55,000 psi min. (eg MS35206 or AN526)

Washer: # 8 AN960

Locking Feature: Self Locking Nut Plate, Self Locking Nut or Lock Washer (AN365)

2.6.1 UNIT INSTALLATION/REMOVAL

To install the SL70R in the mounting frame slide the unit into the frame and turn the DZUS fastener clockwise with a DZUS screwdriver. If a DZUS screwdriver is not available some flat bladed screwdrivers may work. Push the unit fully into the frame, then turn the DZUS lock.

To remove the SL70R from the mounting frame use a DZUS screwdriver or flat bladed screwdriver to turn the DZUS fastener counterclockwise. The unit must be pulled out of the frame by the handle after the DZUS fastener is turned. No special extraction tools are required.

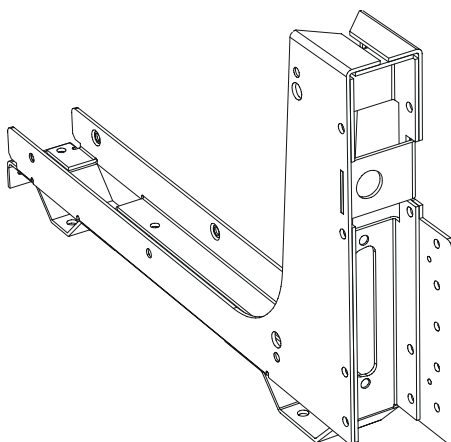

Figure 2-2. Mounting Tray for SL70R

2.7 ELECTRICAL CONNECTIONS

The SL70R installation kit includes a 37 pin D-sub shell and crimp contacts. The crimp contacts are specified for 20 to 24 AWG wire. Make the crimp connections with a crimp tool as specified in the ‘Special Tools Required’ section on page 7. All wires should be 20 to 24 AWG unless otherwise specified.

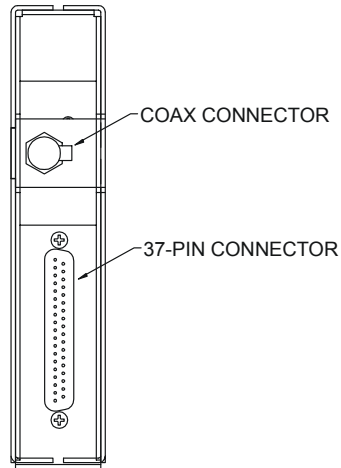
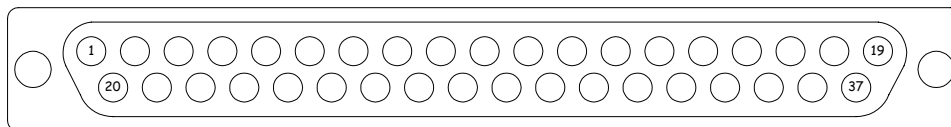

Figure 2-3. Rear View of SL70R

2.7.1 INTERFACE CONNECTOR DEFINITION

Table 2-1 Rear Connector Pinout

Pin #	I/O	Connection	Function
1	I	Power +	main DC power input
2	I	Power ground	main DC power ground
3	O	Serial ground	RS-232 serial ground
4	I	RxD1	RS-232 serial data input
5	O	TxD1	RS-232 serial data output
6	O	Reserved	
7	O	Reserved	
8	I	Reserved	
9	I	Reserved	
10	I	Ident	remote ident input (ground momentarily for ident)
11	--	NC	no connection
12	I	A4	A4 altitude gray code input
13	I	A1	A1 altitude gray code input
14	I	B2	B2 altitude gray code input
15	I	C4	C4 altitude gray code input
16	I	C1	C1 altitude gray code input
17	--	Reserved	
18	--	Reserved	
19	I	Suppress	remote suppression input (high for suppression)
20	O	NC	no connection
21	I	Reserved	
22	O	TxD2	RS-232 serial data output – Duplicates TxD1 data
23	--	NC	no connection
24	--	Ground	
25	I	Reserved	
26	I	Reserved	
27	--	Ground	
28	--	Ground	
29	I	Standby	remote standby input (ground for standby)
30	--	Ground	
31	I	A2	A2 altitude gray code input
32	I	B4	B4 altitude gray code input
33	I	B1	B1 altitude gray code input
34	I	C2	C2 altitude gray code input
35	I	D4	D4 altitude gray code input
36	--	GP I/O 0	Altitude Source Select
37	--	Ground	



Viewed from rear of unit

2.8 ANTENNA INSTALLATION AND CONNECTIONS

The antenna should be mounted in a vertical position in an area on the bottom of the aircraft away from other antennas or landing gear.

The antenna coax cable should be a double shielded low loss cable and must have a cable loss of < 3 dB at 1090MHz, including connectors. A typical installation should have a cable loss of $1\frac{1}{2}$ to 2 dB. Several suitable coaxes are RG142B and RG400.

The assembly of the rear panel coax connector included with the installation kit is illustrated in the following figure.

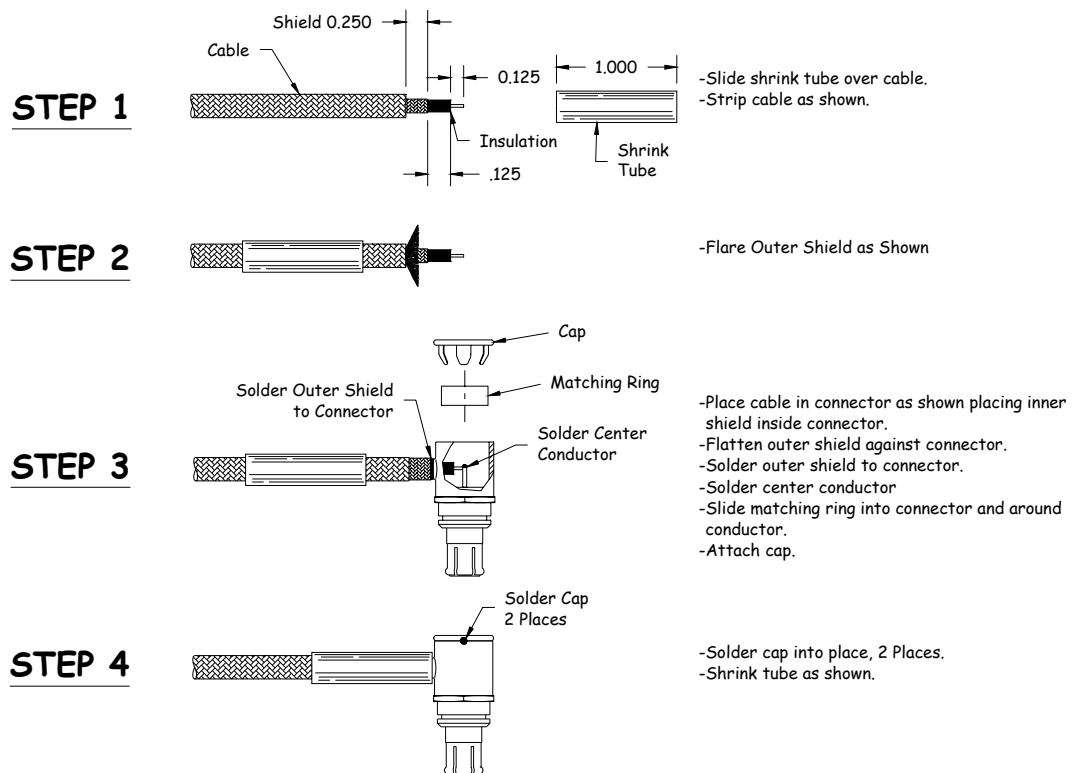
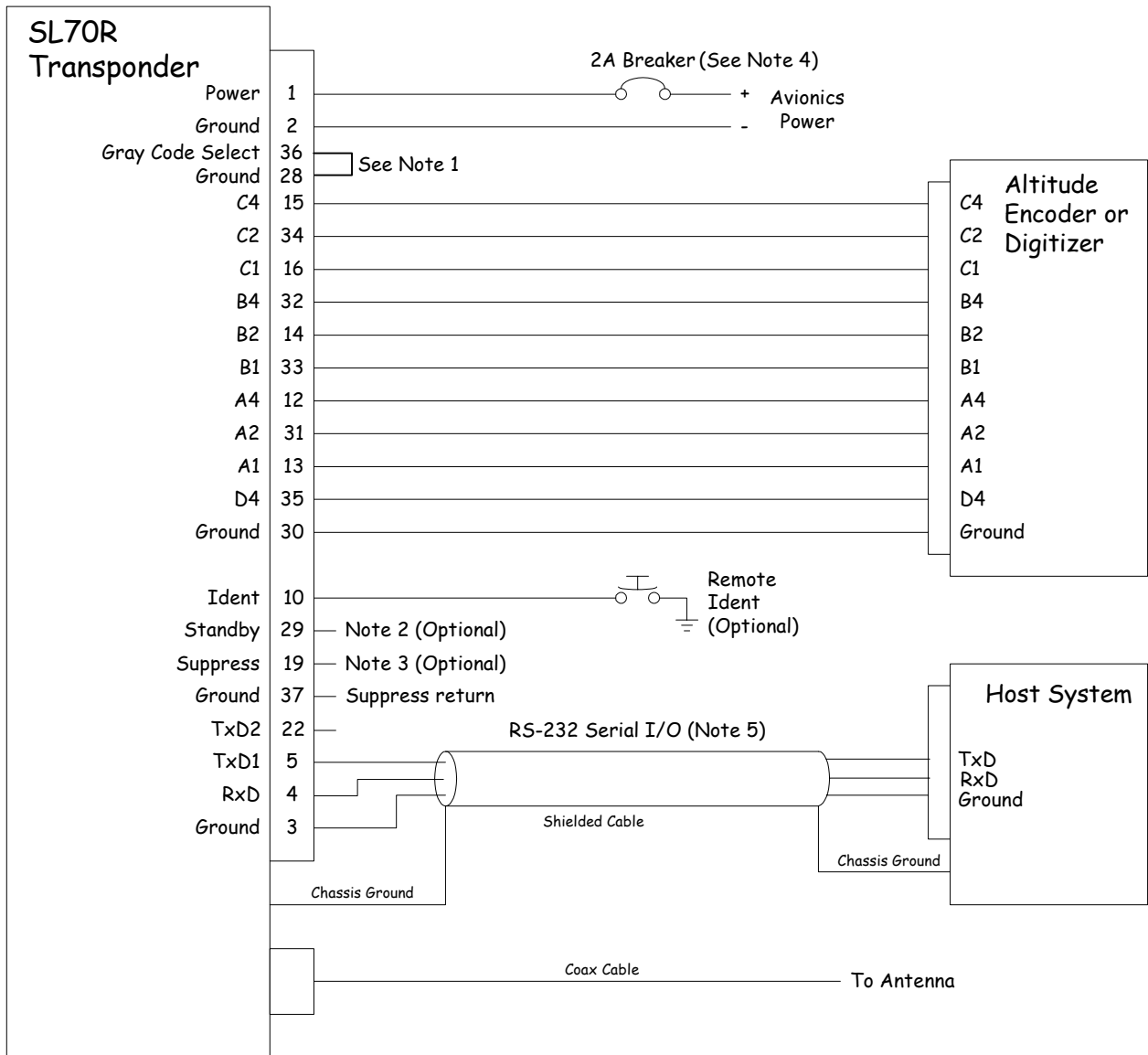

Figure 2-4. Coax Cable Assembly



Notes:

1. Select the gray code input by grounding pin 36 to pin 28 when using the parallel gray code altitude input. For serial altitude, pin 36 is left open.
2. Use standby input to select between two transponders using a selector switch. Unit is in standby when input switched to ground.
3. Suppression input, typically connected to DME suppression output. Transponder is suppressed when input is high.
4. Breaker (or switch) must be accessible by pilot. See Section 2.3.
5. The length of cable used for the serial connection between the SL70R and the host should not exceed 20 feet.

Figure 2-5. Wiring Diagram - Gray Code Altitude Input

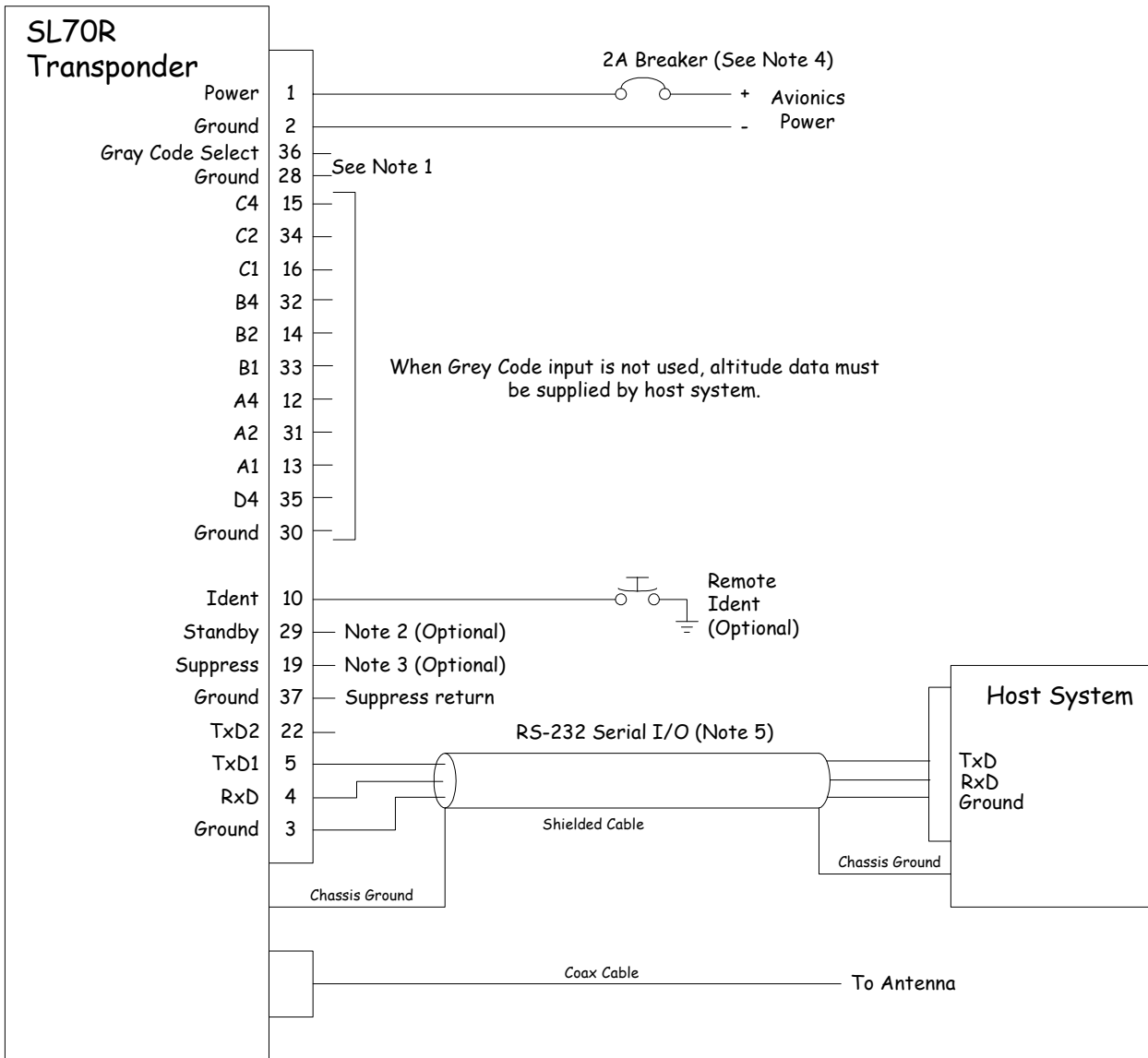

Notes:

1. Select the gray code input by grounding pin 36 to pin 28 when using the parallel gray code altitude input. For serial altitude, pin 36 is left open.
2. Use standby input to select between two transponders using a selector switch. Unit is in standby when input switched to ground.
3. Suppression input, typically connected to DME suppression output. Transponder is suppressed when input is high.
4. Circuit breaker (or switch) must be accessible to pilot. See Section 2.3.
5. The length of cable used for the serial connection between the SL70R and the host should not exceed 20 feet.

Figure 2-6. Wiring Diagram – Host Serial Altitude Input

NOTES

NOTES

3. POST INSTALLATION AND CONFIGURATION PROCEDURES

Once the unit is installed, complete the checkout procedure to verify proper operation.

The steps that are not applicable to a particular installation may be skipped. Fill out the checkout log sheet during the checkout procedure. The log sheet on page 18 may be photocopied if desired.

3.1 MOUNTING / WIRING CHECK

Verify that all cables are properly secured and shields are connected to the rear of the mounting frame.

3.2 EQUIPMENT SETUP AND CONFIGURATION

3.2.1 ALTITUDE INPUT SOURCE SELECTION

The SL70R can use altitude data from either a standard gray code altitude input or from the host system.

If using the gray code altitude input, connections can be made directly from the SL70R to the altitude source. Isolation diodes are included within the SL70R. Make sure a common ground connection exists, or connect a ground wire between the source and the SL70R.

The altitude source must be accurate to within ± 125 feet, 95% probability, and have a resolution of 100 feet (the host input resolution may be better than 100 feet).

3.2.2 RS-232 BAUD RATE SELECTION

The baud rate is fixed at 9600. The host system must communicate with the SL70R at this rate. (8 data bits, 1 stop bit, no parity)

3.3 EQUIPMENT OPERATIONAL/FUNCTIONAL TEST

3.3.1 SELF TEST

The SL70R includes a self test that is executed every time the unit is turned on that checks the receiver and transmitter operation as well as other internal functions.

The host system should verify that the SL70R does not report a failure indication when turned on.

NOTE: The system status message reports the failures.

NOTES

NOTES

4. TROUBLESHOOTING

4.1 TROUBLESHOOTING PROCEDURE

This appendix provides information to assist troubleshooting if problems occur after completing the installation. Use Table 4-1 to assist in troubleshooting.

Table 4-1. Troubleshooting Guide		
Problem	Cause	Solution
The SL70R does not power on.	The unit is not getting power.	Check power connections, breakers, and main avionics switch.
The altitude is not correct.	The unit is not getting the correct altitude.	If the gray code inputs are used, check all connections from the altitude source and/or verify the altitude source.
		If the host is providing serial altitude input check for the correct baud rate and connections.
The unit fails the start-up self-test. NOTE: System status message will report failures.	TX fails.	Check antenna connections. May have an open, a short, or a bad VSWR.
	Other failure.	The unit may need repair. Contact the factory for assistance.
The unit does not generate replies.	The unit is in standby.	The unit must be in either the "On" or "Alt" modes to generate replies.
	The unit is not receiving interrogation signals.	Check the antenna connections.
	No interrogation signal available.	Need to either use a ramp test set or climb to altitude where ATC radar service is available.

4.2 CONTACTING THE FACTORY FOR ASSISTANCE

If the Apollo SL70R unit fails to operate despite troubleshooting efforts, contact the UPS Aviation Technologies factory for assistance.

UPS Aviation Technologies
2345 Turner Rd. SE
Salem, Oregon 97302
U.S.A.

Phone: 503.581.8101 or 800.525.6726

Be prepared to offer the following information about the installation:

- Installation configuration (accessories, antenna, ...)
- Model number, part number with mod levels, and serial number
- Description of problem
- Efforts made to isolate the problem

NOTES

NOTES

5. LIMITATIONS

5.1 INSTALLATION

Aircraft installation must be made in accordance with this installation manual, host system requirements and applicable FAA regulations and advisory circulars. (See Environmental Qualification Form – Appendix A).

5.2 OPERATIONAL

The SL70R must be operated within the limitations as follows, or by other regulatory guidance as appropriate.

1. The altitude reply data may be verified by comparing the pressure altitude reported to the aircraft altimeter relative to a barometric setting of 29.92.
2. The transponder is to be operated in compliance with CFR 14 section 91.215 for ATC transponder and altitude reporting equipment.
3. The transponder must be tested as specified in CFR 14 section 91.413 within the previous 24 months.

Limitations

NOTES

6. PERIODIC MAINTENANCE

The Apollo SL70R does not require any regular general maintenance except as included in this section.

6.1 BIENNIAL CHECK

The transponder must be tested within the previous 24 months as specified in 91.413 of the FAA regulations. No other periodic maintenance is required.

NOTES

7. SERIAL INTERFACE SPECIFICATION

7.1 INTRODUCTION

This section is a specification of the SL70R Mode A/C Transponder serial input and output.

7.2 GENERAL REQUIREMENTS

7.2.1 HOST INTERFACE

The SL70R communicates with a “host” unit such as a navigation computer or a control panel. Any device connected to the SL70R’s external serial port will be referred to as the “host.”

7.2.2 HARDWARE INTERFACE

The SL70R’s external RS-232 port can be found on the 37-pin D sub connector located on the back of the unit.

7.2.3 BAUD RATE

The baud rate is fixed at 9600 baud.

Baud Rate:	9600
Data Bit:	8 bits
Stop Bit:	1 bit
Parity:	None

7.2.4 COMMUNICATIONS

Establishing communications between the SL70R and the host is independent of which device is turned on first. The SL70R operates in a broadcast mode. Once the startup is finished, the SL70R will begin sending the appropriate serial data and processing any incoming serial data.

7.2.5 MESSAGE DEFINITIONS

These messages support the basic operation of the SL70R module.

7.3 OUTPUT MESSAGES

Msg ID	Description	Notes
#AL	Altitude Message	1 second interval approximate
^SS	System Status	On power up & continuously upon failure
^MD	Operation Mode Message	1 second interval approximate
^AH	Alt Hold Message	1 second interval approximate
^RC	Replies per second	1 second interval approximate
^C1	Configuration 1 - Software Versions	Upon request

7.3.1 ALTITUDE

The altitude output function is intended to interface with other Apollo products that have serial altitude input.

7.3.1.1 INTERFACE SPECIFICATION

Output Rate: Approximately 1 second
 Buffer Length: 17 bytes

7.3.1.2 ALTITUDE FORMAT SPECIFICATION

Byte	Contents	Description
0	'#'	ASCII '#' (0x23)
1	'A'	ASCII 'A' (0x41)
2	'L'	ASCII 'L' (0x4C)
3	' '	ASCII space (0x20)
4	'+' or '-'	Altitude sign; ASCII '+' or '-' (0x2B or 0x2D)
5-9	dddd	Altitude in feet (100 ft resolution)
10-13	'T+15'	Temperature (always +15)
14-15	dd	Checksum of bytes 0 through 13. In hex ASCII i.e. "FA"
16	'\r'	ASCII carriage return (0x0D)

7.3.1.3 ALTITUDE FORMAT SPECIFICATION EXAMPLES

#AL +00100T+15D1 100 feet above sea level (@29.92 inches Hg) with temperature @+15°C

#AL -09981T+15ED ERROR CODE invalid data @+15°C

7.3.1.4 ALTITUDE ERROR CODES

The altitude encoder/converter may place an error code in bytes 4-9. Here is a list of the possible codes:

- -09981=Possible Hardware Problem

The converter issues this code if the temperature of the internal heater is greater than 55°C, indicating a possible hardware problem or the data received from the encoder is invalid indicating a possible encoder or wiring problem.

- -09982=Altitude Out of Range

Both the encoder and converter will send this code when the altitude is outside the specified limits for the device.

7.3.2 MODE MESSAGE

The mode message indicates the current operating mode. It includes the following: 1) current mode, Standby, Mode A or Mode C, 2) Ident enabled/disabled, 3) current Squawk code setting and 4) heart beat received. This message is output in both normal and test modes.

7.3.2.1 INTERFACE SPECIFICATION

Output Rate: Approx. 1 sec. when EXT (extended) messages are selected.
Buffer Length 17 bytes

7.3.2.2 MODE FORMAT SPECIFICATION

Table 7-3. Mode Message Format		
Byte	Contents	Description
0	‘^’	ASCII ‘^’ (0x5E)
1	‘M’	ASCII ‘M’ (0x4D)
2	‘D’	ASCII ‘D’ (0x44)
3	‘ ’	ASCII space (0x20)
4	m	See Mode Table below
5	‘,’	ASCII comma (0x2C)
6	i	See Ident Table Below
7	‘,’	ASCII comma (0x2C)
8-11	dddd	ASCII Squawk code
12-13	hh	LSB = 1 heart beat received In hex ASCII “01”
14-15	dd	Checksum of bytes 0 through 13. In hex ASCII i.e. “FA”
16	‘\r’	ASCII carriage return (0x0D)

Table 7-4. Mode Table		
m	Definition	ASCII
O	Standby Mode	0x4F
A	Mode A	0x41
C	Mode C	0x43

Table 7-5. Ident Table		
i	Definition	ASCII
I	Ident Enabled	0x49
-	Ident is Inactive	0x2D

7.3.2.3 MODE MESSAGE EXAMPLES

^MD O,-,12000006 Standby Mode, Ident inactive, Squawk code is 1200
^MD A,I,23540120 Mode A, Ident active, Squawk code is 2354

7.3.3 REPLY COUNT

The reply count message indicates the number of replies per second that are being sent.

7.3.4 INTERFACE SPECIFICATION

Output Rate: Approx. 1 sec. when EXT (extended) messages are selected.

Buffer Length 11 bytes

7.3.4.1 REPLY COUNT FORMAT SPECIFICATION

Byte	Contents	Description
0	‘^’	ASCII ‘^’ (0x5E)
1	‘R’	ASCII ‘R’ (0x52)
2	‘C’	ASCII ‘C’ (0x43)
3	‘ ’	ASCII space (0x20)
4-7	dddd	ASCII Digit (ex. 1234)
8-9	dd	Checksum of bytes 0 through 7. In hex ASCII i.e. “FA”
10	‘r’	ASCII carriage return (0x0D)

7.3.4.2 REPLY COUNT FORMAT SPECIFICATION EXAMPLES

^RC 1200D6 1200 replies per second

7.3.5 CONFIGURATION MESSAGE

This message provides a way to send configuration information. C1 – contains the software version numbers for the microcontroller and FPGA.

7.3.5.1 INTERFACE SPECIFICATION

Output Rate: Upon Request.

Buffer Length 16 bytes

7.3.5.2 SOFTWARE VERSION FORMAT SPECIFICATION

Byte	Contents	Description
0	‘^’	ASCII ‘^’ (0x5E)
1	‘C’	ASCII ‘C’ (0x43)
2	‘1’	ASCII ‘1’ (0x31)
3	‘ ’	ASCII spaces (0x20)
4-5	dd	Micro SW major revision number
6	d	Micro SW minor revision number
7	‘,’	ASCII comma (0x2C)
8	d	FPGA major revision number
9	d	FPGA minor revision number
10	c	Transponder Configuration C= Mode A/C S= Mode S
11-12	xx	Reserved for future use fill with spaces (0x20)
13-14	dd	Checksum of bytes 0 through 8. In hex ASCII i.e. “FA”
15	‘r’	ASCII carriage return (0x0D)

7.3.5.3 CONFIGURATION 1 EXAMPLE

^C1 010,10C 93 Micro SW Version 010, FPGA SW version 1.0 Mode A/C Transponder

7.3.6 SYSTEM STATUS

The system status message contains the 14 bits of status information as defined below in Table 7-8. When a bit is set the particular item is functioning properly.

Table 7-8. Self-Test Bit Definition	
Bit #	Definition
0	3.3 Volt Power Supply
1	5 Volt Power Supply
2	8 Volt Power Supply
3	12 Volt Power Supply
4	45 Volt Power Supply
5	High Voltage Power Supply
6	Input Voltage
7	Discrete Input Reference V
8	Display Temperature
9	Transmitter Temperature
10	Photo Cell
11	Synthesizer Locked
Bit #	Definition
12	Receiver Test
13	Transmitter test
14	Suppression Stuck
15	Unused

7.3.6.1 INTERFACE SPECIFICATION

Output Rate: At Start up and continuously upon fail condition at 1 second intervals.
 Buffer Length 11 bytes

7.3.6.2 SYSTEM STATUS FORMAT SPECIFICATION

Table 7-9. Software Version Message Format		
Byte	Contents	Description
0	‘^’	ASCII ‘^’ (0x5E)
1	‘S’	ASCII ‘S’ (0x53)
2	‘S’	ASCII ‘S’ (0x53)
3	‘ ‘	ASCII spaces (0x20)
4-7	dddd	Status Data Hex ASCII
8-9	dd	Checksum of bytes 0 through 8. In Hex ASCII i.e. “FA”
10	‘\r’	ASCII carriage return (0x0D)

7.3.6.3 SYSTEM STATUS MESSAGE EXAMPLE

^SS FFFF3C no failures
 ^SS FFFE3B 3.3 volt supply failure.

7.4 INPUT MESSAGES

The following messages are processed during normal operation. The AL and SW messages are also processed during setup and test modes.

Msg ID	Description	Notes
#AL	Altitude Message	Must be selected in set up mode or it will be ignored.
#MD	Set Mode Message	Set mode A/C or STBY, IDENT and squawk code
#SW	Request Software Version	SL70R replies with Software Version Message
#RS	Reset	SL70R will reset after approximately 1 second.
#SO	Set Operating Mode	Setup or Test Modes

7.4.1 ALTITUDE

The altitude-input function is intended to interface with serial altitude encoders. The altitude source is selected during installation and must be set to Serial for this message to be processed. Once selected the SL70R must receive a valid message at least once every 2 seconds or the altitude will time out and become invalid until the next valid message is received.

7.4.1.1 INTERFACE SPECIFICATION

Buffer Length 17 bytes

7.4.1.2 ALTITUDE FORMAT SPECIFICATION

Byte	Contents	Description
0	'#'	ASCII '#' (0x23)
1	'A'	ASCII 'A' (0x41)
2	'L'	ASCII 'L' (0x4C)
3	' '	ASCII space (0x20)
4	'+' or '-'	Altitude sign; ASCII '+' or '-' (0x2B or 0x2D)
5-9	dddd	Altitude in feet (right justified with zeros)
10	'T'	ASCII 'T' (0x54)
11	'+' or '-'	Temperature sign; ASCII '+' or '-' (0x2B or 0x2D)
12-13	dd	Internal Altimeter Temperature
14-15	dd	Checksum of bytes 0 through 13. In hex ASCII i.e. "FA"
16	'\r'	ASCII carriage return (0x0D)

7.4.1.3 ALTITUDE FORMAT SPECIFICATION EXAMPLES

#AL +02100T+25D4 2100 feet above sea level (@29.92 inches Hg) with temperature @+25°C

#AL -00045T+45DE 45 feet below sea level (@29.29 inches Hg) with temperature @+45°C

#AL -09980T-12E6 ERROR CODE (temp below +25°C) with temperature @-12°C

7.4.1.4 ALTITUDE ERROR CODES

The altitude encoder/converter may place an error code in bytes 4-9. Here is a list of the possible codes:

- -09980=Heater Not Ready
The encoder issues this code while the unit is in the warm-up phase.
- -09981=Possible Hardware Problem
The converter issues this code if the temperature of the internal heater is greater than 55°C, indicating a possible hardware problem or the data received from the encoder is invalid indicating a possible encoder or wiring problem.
- -09982=Altitude Out of Range
Both the encoder and converter will send this code when the altitude is outside the specified limits for the device.

7.4.2 MODE

The mode message sets the unit's current operating mode. This includes: 1) selecting Standby, Mode A or Mode C, 2) enabling Ident 3) adjusting squawk code. This message is not processed when in setup or test modes. It will also not be process if a system failure has occurred.

7.4.2.1 INTERFACE SPECIFICATION

Buffer Length 15 bytes

7.4.2.2 MODE FORMAT SPECIFICATION

Byte	Contents	Description
0	'#'	ASCII '#' (0x23)
1	'M'	ASCII 'M' (0x4D)
2	'D'	ASCII 'D' (0x44)
3	' '	ASCII space (0x20)
4	m	See Mode Table below
5	','	ASCII comma (0x2C)
6	i	See Ident Table Below
7	','	ASCII comma (0x2C)
8-11	Dddd	ASCII Squawk code
12-13	Dd	Checksum of bytes 0 through 11. In hex ASCII i.e. "FA"
14	'\r'	ASCII carriage return (0x0D)

m	Definition	ASCII
O	Standby Mode	0x4F
A	Mode A	0x41
C	Mode C	0x43

i	Definition	ASCII
I	Ident Enabled	0x49
-	Ident is disabled	0x2d

7.4.2.3 MODE MESSAGE EXAMPLES

#MD O,-,12006B Standby Mode, Ident inactive, Squawk code is 1200
 #MD A,I,235484 Mode A, Ident active, Squawk code is 2354

7.4.3 SOFTWARE VERSION

The software version message requests the software version be sent. In response the SL70R will send the configuration message which includes the software versions.

7.4.3.1 INTERFACE SPECIFICATION

Buffer Length 6 bytes

7.4.3.2 SOFTWARE VERSION MESSAGE SPECIFICATION

Byte	Contents	Description
0	'#'	ASCII '#' (0x23)
1	'S'	ASCII 'S' (0x53)
2	'W'	ASCII 'W' (0x57)
3-4	'CD'	Checksum = CDH
5	'\r'	ASCII carriage return (0x0D)

7.4.4 RESET

The reset message will cause the SL70R to reset. It will take approximately 1 second for the unit to reset after receiving the message.

7.4.4.1 INTERFACE SPECIFICATION

Buffer Length 6 bytes

7.4.4.2 RESET MESSAGE SPECIFICATION

Byte	Contents	Description
0	'#'	ASCII '#' (0x23)
1	'R'	ASCII 'R' (0x52)
2	'S'	ASCII 'S' (0x53)
3-4	'C8'	Checksum = C8H
5	'\r'	ASCII carriage return (0x0D)

7.4.5 SET OPERATION

This message sets the SYS_BOOT register in the eeprom and then forces the system to reset. To exit setup mode, turn unit off, then back on.

7.4.5.1 INTERFACE SPECIFICATION

Buffer Length 8 bytes

7.4.5.2 SET OPERATION FORMAT SPECIFICATION**Table 7-17. P1 Pulse Message Format**

Byte	Contents	Description
0	'#'	ASCII '#' (0x23)
1	'S'	ASCII 's' (0x53)
2	'O'	ASCII 'O' (0x4f)
3	' '	ASCII space (0x20)
4	'd'	ASCII argument see table below
5-6	dd	Checksum of bytes 0 through 4. In hex ASCII i.e. "FA"
7	'\r'	ASCII carriage return (0x0D)

Table 7-18. Arguments

	Definition	ASCII
1	Setup Mode	31

7.4.5.3 SET OPERATION EXAMPLES

#SO 116 Set operation to setup mode

7.5 SETUP MODE MESSAGE DEFINITIONS**7.5.1 OUTPUT MESSAGES**

Note: Normal output messages are also output in setup mode.

7.5.2 EEPROM DATA

The eeprom data message provides the 16-bit data at the specified eeprom location. The location is specified by the view eeprom serial message, see section 7.5.6.

7.5.2.1 INTERFACE SPECIFICATION

Buffer Length 14 bytes

7.5.2.2 EEPROM DATA FORMAT SPECIFICATION**Table 7-19. EEPROM Data Message Format**

Byte	Contents	Description
0	'^'	ASCII '^' (0x5E)
1	'E'	ASCII 'E' (0x45)
2	'E'	ASCII 'E' (0x45)
3	' '	ASCII space (0x20)
4-5	dd	In hex ASCII i.e. "1F"
6	,	ASCII comma (0x2C)
7-10	dddd	Data Value In hex ASCII i.e. "1F89"
11-12	dd	Checksum of bytes 0 through 10. In hex ASCII i.e. "FA"
13	'\r'	ASCII carriage return (0x0D)

7.5.2.3 EEPROM DATA MESSAGE EXAMPLES

^EE 13,FFFFB0 EEprom location 13H contains FFFFH

7.5.3 INPUT MESSAGES

The input messages #AL (altitude), #SW(software version request) and #RS(reset request) are supported in setup mode. In addition the following messages are also supported.

Table 7-20. Setup/Test Mode Output Messages

Msg ID	Description	Notes
#IE	Init EEProm	
#SV	Set VFR Code	
#VE	View EEprom location	

7.5.4 INIT EEPROM

This message causes the eeprom to reset to factory default settings. Unit must be in setup mode.

7.5.4.1 INTERFACE SPECIFICATION

Buffer Length 6 bytes

7.5.4.2 INIT EEPROM FORMAT SPECIFICATION

Table 7-21. Init EEProm Message Format

Byte	Contents	Description
0	'#'	ASCII '#' (0x23)
1	'I'	ASCII 'I' (0x49)
2	'E'	ASCII 'E' (0x45)
3-4	'B1'	Checksum = B1H
5	'\r'	ASCII carriage return (0x0D)

7.5.4.3 INIT EEPROM EXAMPLE

#IEB1 Initialize EEProm

7.5.5 SET VFR

This message sets the default VFR code. The squawk code is set to the VFR code when the unit is powered up or VFR button is initially pressed. Unit must be in setup mode.

7.5.5.1 INTERFACE SPECIFICATION

Buffer Length 11 bytes

7.5.5.2 SET VFR FORMAT SPECIFICATION

Table 7-22 VFR Message Format

Byte	Contents	Description
0	'#'	ASCII '#' (0x23)
1	'S'	ASCII 'S' (0x53)
2	'V'	ASCII 'V' (0x56)
3	' '	ASCII space (0x20)
4-7	'dddd'	ASCII Squawk code
8-9	dd	Checksum of bytes 0 through 7. In hex ASCII i.e. "FA"
10	'\r'	ASCII carriage return (0x0D)

7.5.5.3 SET VFR EXAMPLE

#SV 4321B6 Set default VFR code to 4321

7.5.6 VIEW EEPROM

The view eeprom command request that the eeprom data at the specified location be sent. In response the SL70 will send the eeprom data message, see 7.5.2.

7.5.6.1 INTERFACE SPECIFICATION

Buffer Length 9 bytes

7.5.6.2 VIEW EEPROM FORMAT SPECIFICATION**Table 7-23 View EEPROM Format**

Byte	Contents	Description
0	'#'	ASCII '#' (0x23)
1	'V'	ASCII 'V' (0x56)
2	'E'	ASCII 'E' (0x45)
3	' '	ASCII space (0x20)
4-5	'dd'	Hex ASCII Location i.e. "13" up to 7FH
6-7	dd	Checksum of bytes 0 through 5. In hex ASCII i.e. "FA"
8	'\r'	ASCII carriage return (0x0D)

7.5.6.3 VIEW EEPROM EXAMPLE

#VE 1342 View eeprom location 13H

NOTES

APPENDIX A. ENVIRONMENTAL QUALIFICATION FORM

The Apollo SL70R has been tested to the following environmental categories per procedures defined in RTCA/DO-160D.

Environmental Qualification Form		
Nomenclature: Apollo SL70R Part No.: 430-6067-xx TSO No.: TSO_C74c		Manufacturer: UPS Aviation Technologies 2345 Turner Road SE Salem, Oregon 97302
Conditions	Section	Description of Conducted Tests
Temperature and Altitude	4.0	Equipment tested to Category B1 with:
In-flight Loss of Cooling	4.5.4	No cooling required
Altitude	4.6.1	Equipment tested to 25,000 feet
Decompression	4.6.2	Equipment tested for decompression to 25,000 feet
Overpressure	4.6.3	Equipment tested for overpressure
Temperature Variation	5.0	Equipment tested to Category C, 2°C/min
Humidity	6.0	Equipment tested to Category A, standard humidity environment
Operational Shocks and Crash Safety	7	Equipment tested for both operational and crash safety shocks. (Equipment operates normally after crash safety and operational shock.)
Vibration	8.0	Equipment tested without shock mounts to Categories S(B,M)
Explosion Proofness	9.0	Equipment identified as Category X, no test required
Waterproofness	10.0	Equipment identified as Category X, no test required
Fluids Susceptibility	11.0	Equipment identified as Category X, no test required
Sand and Dust	12.0	Equipment identified as Category X, no test required
Fungus Resistance	13.0	Equipment identified as Category X, no test required
Salt Spray	14.0	Equipment identified as Category X, no test required
Magnetic Effect	15.0	Equipment is Class Z
Power Input	16.0	Equipment tested to Categories A (28 volt systems) & B (14 and 28 volt systems)
Voltage Spike	17.0	Equipment tested to Category A
Audio Frequency Conducted Susceptibility – Power Inputs	18.0	Equipment tested to Categories A & B
Induced Signal Susceptibility	19.0	Equipment tested to Category Z
Radio Frequency Susceptibility (Radiated and Conducted)	20	Equipment tested to Category V
Emission of Radio Frequency Energy	21	Equipment tested to Category M*
Lightning Induced Transient Susceptibility	22.0	Equipment tested to A3 and B2
Lightning Direct Effects	23.0	Equipment identified as Category X, no test required
Icing	24.0	Equipment identified as Category X, no test required
Remarks: *TSO requirements do not require emission testing above 1.2GHz. Intentional radiators at the second harmonic, 2.18GHz and at the fourth harmonic, 4.36GHz, may be above the limits as specified by DO-160D. The SL70R meets all of the environmental qualification requirements of TSO-C74c, it was qualified to and met the higher DO-160D standard with the exception as indicated above.		

NOTES

UPS Aviation Technologies

