

TC 11606

# VAN'S AIRCRAFT, INC.

14401 NE Keil Road, Aurora, Oregon, USA 97002

PHONE 503-678-6545 • FAX 503-678-6560 • www.vansaircraft.com • info@vansaircraft.com

---

**FAB-360/540**

**FILTERED AIR BOX-360/540 & F.I. O-320**

October 18, 2005

**CONTENTS:**

1.000 VA-131-A	FIBERGLASS AIR BOX
1.000 VA-131-B	AIR BOX TOP PLATE
1.000 VA-131-C	MOUNT PLATE
1.000 VA-131-D	FILTER RETAINER
1.000 MS20001-4X4 W/5".0	VA-130-F
1.000 AS3-040X3X8	VA-130-G/H
1.000 VA-130-I	FOAM BLOCK FOR FAB
1.000 VA-130-J	COWL SEAL
1.000 VA-122	ARM
1.000 E-3450	AIR FILTER (O-360)
1.000 VA-131-Q	F.I. MIXTRE ARM RECESS
1.000 FAB BYPASS VERTICAL	O-320/360/540
1.000 DOC FAB 320/360/540	FAB INSTRUCTIONS
<b>1.000 BAG 939-1</b>	<b>FAB 360 HARDWARE</b>
4.000 WASHER TAB LOCK 1/4	
1.000 MS21919WDG3	3/16" CUSHIONED CLAMP
4.000 BOLT HEX 1/4-20X1/	BOLT HEX 1/2"
6.000 K1000-3	PLATENUT 10-32
5.000 AN3-4A	BOLT
6.000 AN960-10	WASHER
7.000 RIVET SD-42-BSLF	POP RIVET (BAFFLE)
0.010 AN426AD3-5	RIVETS
0.030 AN470AD3-4	RIVETS
1.000 F 1/4 PIPE PLUG	ALLEN HEAD
1.000 AN3-11A	BOLT
1.000 AT6-058X5/16X4	ALUM TUBE {4" LONG}
1.000 VA-181	WIRE NUT
2.000 AN960-10L	WASHER, THIN
1.000 MS24665-151	COTTER PIN

# VAN'S AIRCRAFT, INC.

14401 NE Keil Road, Aurora, Oregon, USA 97002

PHONE 503-678-6545 • FAX 503-678-6560 • [www.vansaircraft.com](http://www.vansaircraft.com) • [info@vansaircraft.com](mailto:info@vansaircraft.com)

---

FAB BYPASS VERTICAL  
FILTERED AIRBOX BYPASS KIT FOR ALL:  
O-320/360/540 VERTICAL INDUCTION ENGINES  
October 17, 2005

CONTENTS:

1.000 CT A-740 BLACK	PUSH PULL CABLE BLACK
1.000 VA-192A	ALTERNATE AIR INLET
1.000 VA-192B	FILTER BYPASS DOOR
1.000 DOC BYPASS VERTICAL 320/360/540	FILTER BYPASS INSTRUCTIONS

CONTENTS:

BAG 531	VERTICAL BYPASS HDWRE
1.000 WASHER 5610-18-31	NYLON WASHER #8 SCREW
8.000 RIVET AK-42H	POP RIVET
3.000 AN426AD3-3.5	RIVETS
3.000 AN426AD3-4	RIVETS
3.000 AN426AD3-4.5	RIVETS
1.000 AN509-8R8	SCREW, FLAT HEAD
1.000 AN515-8R8	SCREW, ROUND HEAD
1.000 AN525-10R7	SCREW, WASHER HEAD
1.000 AN960-8	WASHER #8
1.000 K1000-08	PLATENUT 8-32
1.000 K1000-3	PLATENUT 10-32
1.000 MS21042-08	832 ALL METAL LOCKNUT
1.000 MS21919WDG3	3/16" CUSHIONED CLAMP

# VAN'S AIRCRAFT, INC.

14401 NE KEIL RD. • AURORA, OREGON 97002 • USA  
PHONE 503-678-6545 • FAX 503-678-6560  
INTERNET [www.vansaircraft.com](http://www.vansaircraft.com)

October 10, 2005

ATTN: Van's Aircraft Kit Aircraft Builders & Pilots.

RE: FAB BYPASS

The filtered airbox kits (FAB-320/360/540 or FAB-HORIZ) were designed to filter all engine induction air with a minimum loss of manifold pressure. The filter facilitates uniform airflow through the carburetor or injection air body to better equalize the mass flow to the individual cylinders. This contributes to maximizing power output and engine smoothness.

It is imperative to remember that, unless the individual aircraft operating limitations permit, experimental aircraft are not permitted to fly into known icing conditions. Flight into forecast icing conditions is limited by the provisions of FAR 91.527. Flight into icing conditions can be extremely dangerous since the rate of ice accumulation in the induction system and on the airframe are unpredictable and may change in seconds.

Pilots who foresee inadvertent flight into heavy snow, freezing rain, or icing conditions, should consider equipping their filtered air box with a FILTER BYPASS. In case of blockage, the filter bypass feature would permit unfiltered air to bypass the filter and directly enter the carburetor/injector air body throat. The enclosed BYPASS KIT kit has been developed and tested by Van's Aircraft Inc. to accomplish the above objective.

FAB-320/360/540: RV's using the vertical induction air box designed for either carburetors or vertical draft fuel injection systems are provided with a provision for pilot-controlled alternate filtered air. The design intent was that when a pilot encountered flight conditions where foreign materials, including snow and freezing rain, might be ingested into the induction air system, he would actuate the alternate air door. This would block the ram air inlet thus preventing further filter blockage and, at the same time, admit warm air from the engine compartment. The addition of the FILTER BYPASS kit simply provides a method to bypass a totally plugged filter in cases where the alternate filtered air door provided is insufficient.

FAB-HORIZ: RV's using the horizontally mounted Bendix or Airflow Performance System fuel injection units do not have an alternate air door and operators should incorporate the FAB BYPASS. The addition of the FILTER BYPASS kit simply provides a method to bypass a totally plugged filter.

Should filter blockage be encountered, the pilot must open the FILTER BYPASS door so that the engine will continue to draw sufficient induction air. The pilot must land the aircraft as soon as practical after opening the filter bypass door so that the filter blockage can be cleared and to reset the filter bypass door.

The FILTER BYPASS door is not designed to be reset from the cockpit. A visual inspection of the filter bypass door must be done to verify that it has been properly reset.

The FILTER BYPASS door is designed for emergency use only and is not to be opened as part of any routine operations.

Van's Aircraft Inc. has developed and supplied this FILTER BYPASS for the purpose of enhancing safety should inadvertent flight into severe and unusual operating conditions occur. Pilots operating any aircraft equipped with a Van's Aircraft Inc. FAB system with the FILTER BYPASS feature should also be aware of other flight hazards (such as airframe and propeller icing) which may result from operating in conditions severe enough to cause filter blockage. Installation of the Filter Bypass system should not be viewed as license to operate in conditions for which the aircraft is not permitted, and/or not equipped to operate safely.

- Van's Aircraft Inc. recommends that this advisory become a permanent part of the aircraft records.
- Please contact Van's Aircraft for further information and availability of filtered airbox modification components.

## INSTALLING THE FAB-320/360/540 FILTERED BOX

The FAB-320/360/540 filtered air box was designed to provide an inexpensive, efficient filtered air induction system that minimizes both intake pressure loss and cowl frontal area. Testing has shown that air filtration is excellent and very little manifold pressure is lost through the filter.

The FAB-320/360/540 draws high energy ram air from outside the cowl through an intake of approximately the same area as the carburetor inlet. The air is then decelerated as it moves into the large filter area of the air box. This deceleration produces high-pressure turbulent airflow. The air then passes through an annular air filter. The large area of the filter helps reduce pressure losses compared to conventional flat filters. For a given flow of air, the velocity through a large filter is lower, helping reduce pressure loss in the intake. The filter not only cleans the air, it also helps filter out much of the turbulence in the airflow. In fact, our installation loses much more manifold pressure when the filter is removed than when it is installed.

The FAB-320/360/540 air box is designed for use in VFR conditions only.

The finished air box has two main parts. See Figure 1A for the O-320 or Figure 1B for the O-360. A flat aluminum top provides easy mounting to the carburetor, enables a simple alternate air gate, and allows the filter to be properly mounted. A curved fiberglass scoop at the bottom of the air box was designed to efficiently direct ram air around the filter.

The FAB-320/360/540 air box must be able to accommodate four different airplanes, two intake locations on the O-360, several carburetor/fuel injectors, and many cowl variations. There are so many combinations possible that a step by step installation procedure for each is impractical. In these instructions we have tried to provide fairly detailed coverage of the most common variations. However, the installer should **READ ALL OF THE INSTRUCTIONS**, understand the installation **BEFORE** starting, and think ahead to integrate and adapt the different procedures to their installation.

These instructions are generic for carbureted engines and the part numbers may not apply to your particular kit. For many, this set of instructions will only provide a starting point or ideas to help the installer.

The air box installation is much easier if the exhaust system is not on the engine. The objective is to properly align the air box assembly with the cowl.

- The mount plate, Fig. 1, is different for the Facet/Precision carburetor and Ellison fuel injector. You will need to cut an extra hole out of the plate when using a Facet carburetor. The extra hole allows for the bowl drain to protrude into the mount plate. Use the template provided as a starting place for the cut out. The carburetor drain plug may interfere with the mount plate. If the carburetor on your engine has a protruding drain plug it must be replaced with the supplied plug.

Most of the MA4-5 carburetors for the O-360/540 have a flashing area on the bottom at each side of the drain plug boss. You can either file this area flush (Plug the ports in the carburetor to keep it clean), or make a spacer the same thickness as the flashing that will allow the VA-131-C to lie flat on the carburetor bottom.

### O-320 ONLY

To allow the filter to sit flush on the mount plate the filter must be trimmed to fit over the accelerator pump. Any gaps between the filter and pump are then filled with silicone rubber (RTV) or fuel tank sealant. The sealant effectively replaces the rubber edge flange that was cut away (Fig. 1A). The filter is first marked to help locate the proper place to cut the clearance hole. The five filter retainers and the drain plug hold the filter to its oval shape. When the filter is aligned flush with the five retainers and the drain plug cutout, mark it through the accelerator pump cutout. Remove the filter and carefully cut it with a single edge razor blade and metal cutting snips to fit over the accelerator pump. Use the marks and carburetor bottom as a guide. Make the hole slightly larger than the pump. Install the mount plate to the carburetor. Coat the accelerator pump, and any areas of the mount plate, that may contact the sealant, with a thin layer of parting agent. The parting agent (a coat of automotive wax or grease works well) keeps the sealant from sticking to the carburetor, pulling apart, and leaving a mess each time the filter is removed. Fill the cutout on the filter with

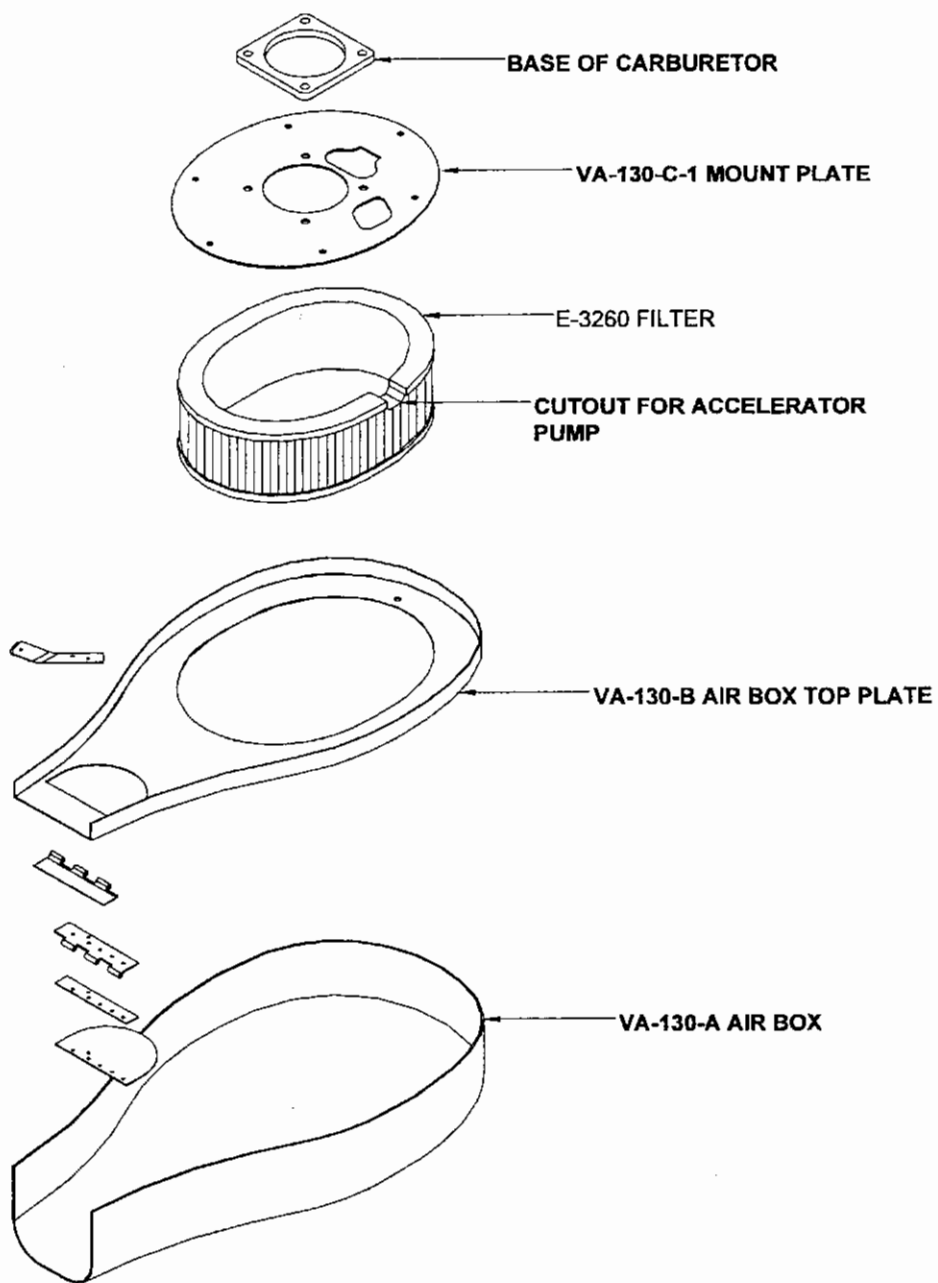
enough sealant to completely fill any gaps between the accelerator pump and the filter. Also apply a little sealant to the bottom of the accelerator pump to assure complete filling of any gap prone areas. Making certain everything is aligned correctly, install the filter. With the carburetor, mount plate and filter in place on the bench, weight the carburetor down on the filter for a good seal. Wipe off any excess sealant and allow at least 24 hours for drying. When dry, the filter can carefully be removed from the mount plate. Be certain the sealant is well cured; a large mass can cure slowly. Use a knife point or screwdriver blade to help lift the sealant from the carburetor. Wipe off any left over grease or wax and cut away any excess sealant left on the filter. During final assembly fill all gaps that would allow unfiltered air to enter between the carburetor and mount plate (especially around the drain plug) with sealant. Make sure that all the sealant is really stuck to the filter to prevent any pieces being sucked into the carburetor.

- The air box must be trimmed to length to fit your engine and cowl. There are two carburetor locations on Lycoming engines. One near the rear of the sump and one near the front. The object here is to allow easy removal of the cowl by allowing you to drop it straight down and clear the spinner. Fig. 9 illustrates this and shows why the air box can't be left long and still allow the cowl to drop down. Trim both the VA-130-B or VA-131-B and the fiberglass air box to look like Fig. 9.
- Estimate where the rivets will go in the flange and flute the top plate to get it flat. Bolt the mount plate to your carburetor. Clamp the top plate to the mount plate. Center carefully and keep the neck on the top plate pointed forward. Now install the lower cowl. Carburetor locations and cowl scoop positions differ from one airplane to the next. Check to make certain that the neck is aligned with the cowl air scoop horizontally (Fig. 3). If not, remove the cowl, realign the neck and check again. If the exhaust system is not installed, you may be able to reach inside the cowl and make the adjustment. When the top plate neck is aligned with the cowl scoop inlet, carefully mark the top plate so that after the clamps are removed realignment is possible. Remove the assembly and drill the top plate using the aligned mount plate as a template, and install the plate nuts and the VA-131-D filter retainers (Fig. 2 & 5) to the top plate. Fabricate the retainers from the material supplied
- Vertical alignment of the top plate can now be checked in much the same manner. Bolt together the mount plate and the top plate, then install on the carburetor. Install the cowl, and check that the top plate neck is vertically flush with the top of the cowl air scoop (Fig. 8). During this procedure it's a good idea to also install the upper cowl to correct any sagging in the lower cowl. Any vertical misalignment is corrected by bending the top plate. Flute or notch the flanges on the top plate and bend it as close to the mount plate as possible (Fig. 3). The bend must be sharp to avoid gaps when the carburetor heat door is open (ram air position). Note: The engine will sag later about 1/8" so you can temporarily put two washers between the mount plate and the carburetor to compensate.
- The filter must be compressed between the mount and the air box in order to provide an air tight seal (Fig 2). To compress the filter, mount the top plate 1/16 inch below the top of the filter. Screw the mount plate to the top plate and place the filter between the assembly and the air box. Compress the filter 1/16" and when satisfied with the fit, drill and cleco the top plate to the air box. Do not drill the rivet holes forward of the bend that you made during vertical adjustment. Check that the opening of the air box inlet matches the opening in the cowl air scoop. If it doesn't match, cut the side of the fiberglass VA-130-A or VA-131-A at the point of the bend in the VA-130-B or VA-131-B. Position the forward end so the height of the opening is correct. Drill the remaining holes. Use polyester resin and glass cloth to close the cut.

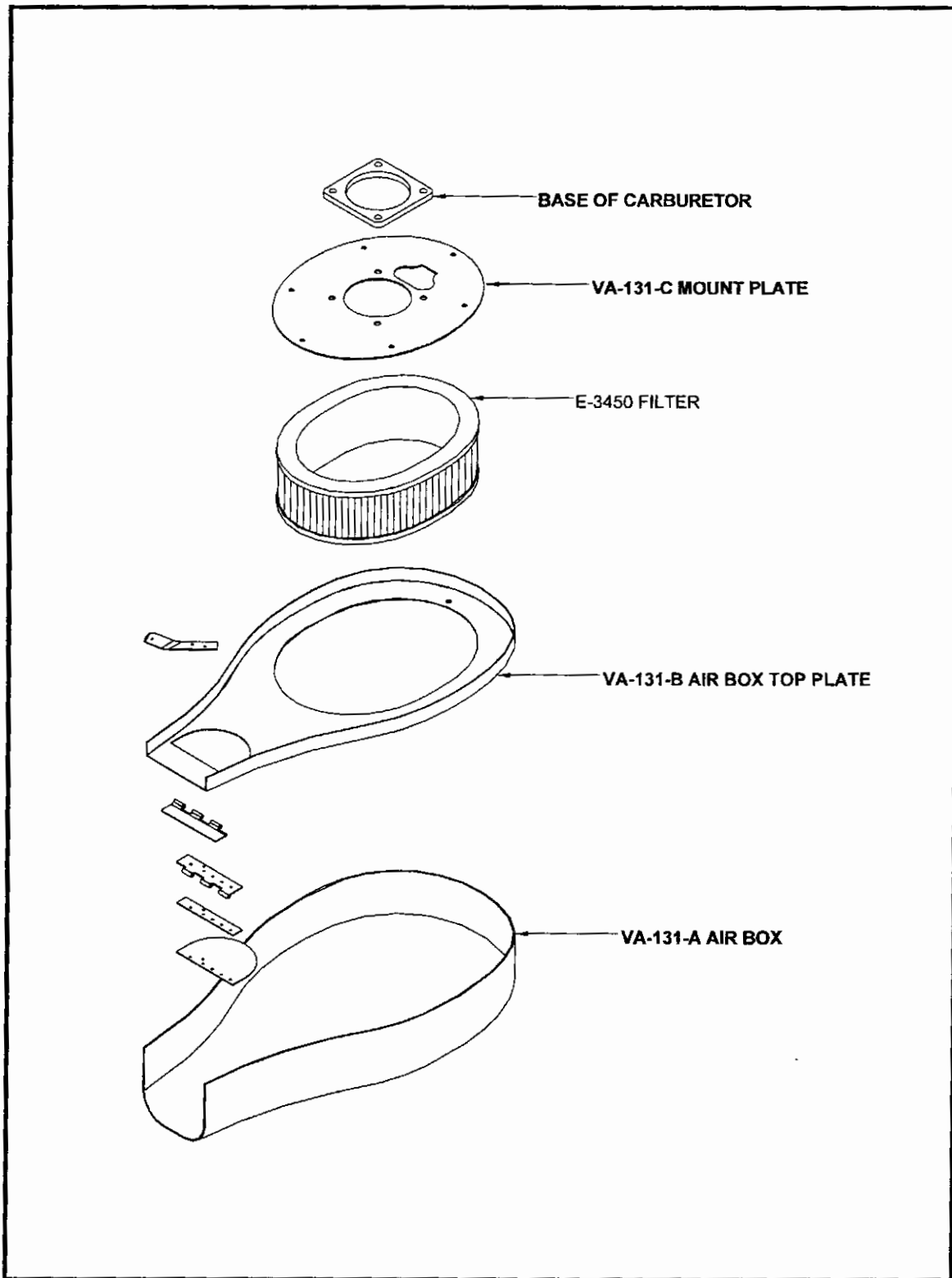
You only need enough flange height around the rest of the VA-130-A or VA-131-A to be able to install the rivets at 1" spacing (Fig 4). Drill two small (1/8") holes through the lowest points of the air box (one inside and one outside of the filter) to allow fuel and water to drain.

- The carburetor heat door (VA-130-H) must be cut to fit the neck of the air box. Due to the varying cross section of the neck, take care to fit the door in the same position that it will be installed (about 1 inch from the entrance of the air box).
- Cut a hole for the carburetor heat intake, starting 1" from the air box entrance. The finished hole will be the same shape as the door but slightly smaller. Use the door as a template, but cut about 1/16" to 1/8" inside the line.
- Being careful to have the flat side of the hinge (VA-130-F) down, drill the hinge and top plate. Reverse the other side of the hinge (flat side up) (Fig. 4) and install the hinge pin. Cleco the hinge to the top plate.

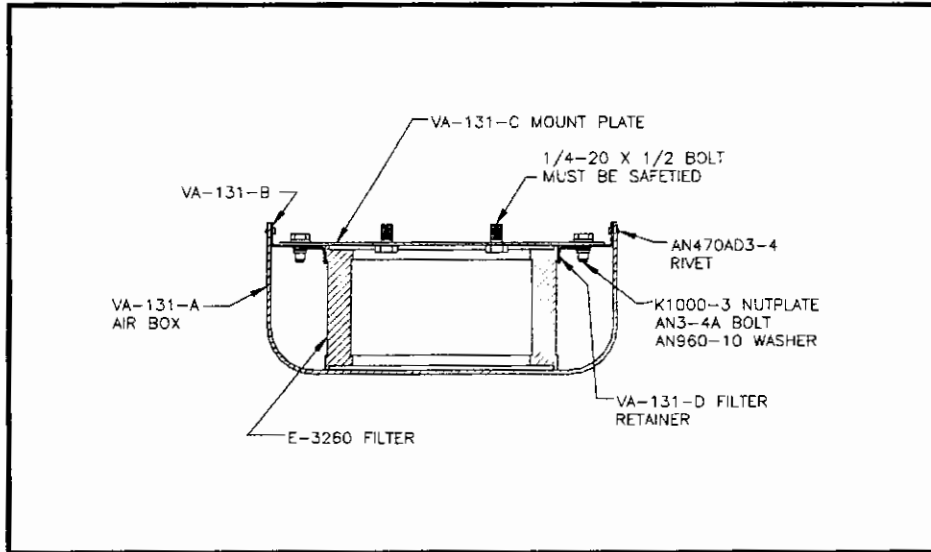
- ❑ Fit the door so that it just touches the air box floor when closed. Then cut the door to its final length for mounting to the hinge. Cut a 9/16" by 3" spacer (VA-130-G) from left over door material to place between the hinge and the door. The hinge, door, spacer, and arm (VA-122) may now be drilled and clecoed together.
- ❑ After reviewing the fit of all the components, rivet the carburetor door assembly together. It may be necessary to trim some of the rivets provided. Finally, rivet the top plate to the air box.
- ❑ The final project is to mate the air box to the air scoop on the cowl. A smooth, tight junction between the air box and cowl can significantly increase maximum manifold pressure. The cowl scoop is extended back almost to the air box using fiberglass laid around a foam mold. The gap is then sealed with rubber engine baffle material to isolate engine vibration. This can be a fairly time consuming procedure. However, the performance gained from a good joint makes the extra effort worthwhile.
- ❑ Install the completed air box and cowling. Measure the distance from the outside of the air scoop to the front of the air box (Fig. 9). Remove the cowling. The cowl air scoop intake lip must be filed or sanded down to avoid decreasing the intake area when the new fiberglass is laid. Taper the amount of material removed, very little at the front of the lip and most of the fiberglass at the rear. Shape the foam block (VA-130-1) to wedge tightly into the cowling behind the air scoop (Fig. 6). Secure the block with two or three fingertip size globs of an adhesive that can later be removed. Bondo, an automotive body filler, works well and can be chipped out when ready. Ideally, the block will be wedged in tight enough to require very little adhesive. Now cut the foam to the same depth as the air box or just a little longer. When you put the cowl back it is OK if the foam contacts the air box. Bore a large hole in the middle of the block and use the distance measured earlier to find the correct location for the cut (Fig. 6). Install the upper and lower cowling. Shape the foam to provide a smooth transition between the air scoop and the air box. A hacksaw blade works well for this. Allow room for the thickness of the fiberglass (approximately 1/16") when shaping near the air box. Leave the foam flush with the inside of the scoop.
- ❑ Remove the cowling and apply three layers of fiberglass to the inside of the foam plug. Use 9 oz. cloth cut so the fibers run 45 degrees off the aircraft centerline (Fig. 7). The 45° weave pattern will permit the cloth to contour to the inlet shape more easily. An epoxy resin, not polyester, should be used. Blow up a balloon inside the inlet to hold the cloth in place while the resin cures. After cure paint on 3 to 4 coats of resin until the weave has been filled. Another layer of fiberglass on the inside of the cowl at the fillet will help secure the new inlet.
- ❑ Chip out the adhesive and foam plug after the fiberglass has cured. The gap between the new trailing edge of the air scoop and the air box should be cut to about 1/4 inch (Fig. 8). Trim the edge to length with a cutting disk in a die grinder. The fiberglass must be finished so it is smooth. File and sand the newly laid fiberglass until it blends well with the cowl and is smooth all the way to the air box.
- ❑ Now install the cowl seal (VA-130-J) around the air box inlet (Fig. 8). The seal is a strip of engine baffle material used to provide a flexible junction between the cowl air scoop and the air box. Start at the top of the box, drill and cleco the middle of the cowl seal to the middle of the top plate. The cowl seal should overlap the air box about 1". Cut one piece to fit across the top with the ends folded up, and another piece will wrap around from the top edge of the first piece all the way around to the other top edge. Pop rivet the seal to the air box in the same order as they were drilled. The seal must be notched where it overlaps the cowl scoop to allow easy installation of the lower cowl. Experiment with only a few notches initially, adding only as many as are necessary to install the cowl.
- ❑ When installing the air box on the carburetor for the final time, the 1/4-20 screws that hold the mounting plate on **must be safetied with the tab lock washers supplied or drilled and safety wired in pairs**. Don't forget to remove the temporary washers that you put in above the mount plate to compensate for engine droop. If the bolts vibrated loose they could be sucked into the engine with catastrophic results.
- ❑ When you install the cable control be sure that the door cannot get stuck in the heat position and that you put a little tension on the cable in the open position. This will keep things from rattling in flight. Also a thin layer of tank sealant on the door where it contacts the top plate will help prevent fretting of the two components.



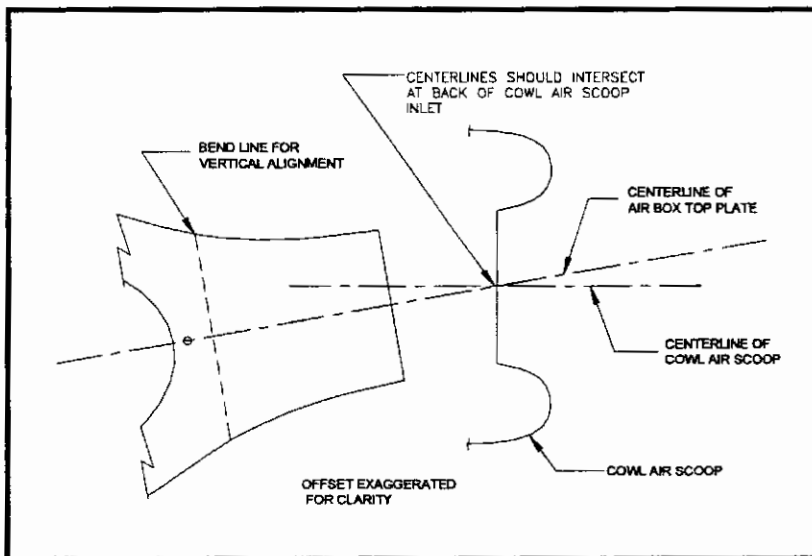
**FIG. 1A**  
**O-320**



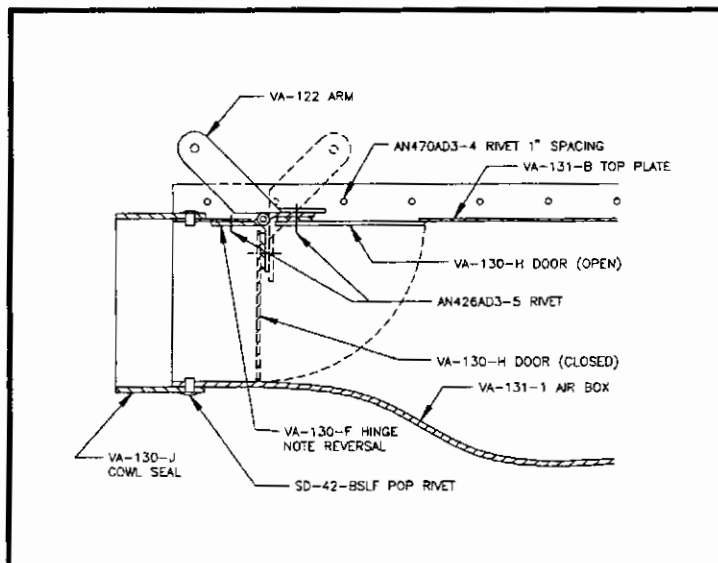
**FIG. 1B**  
**O-360/540**



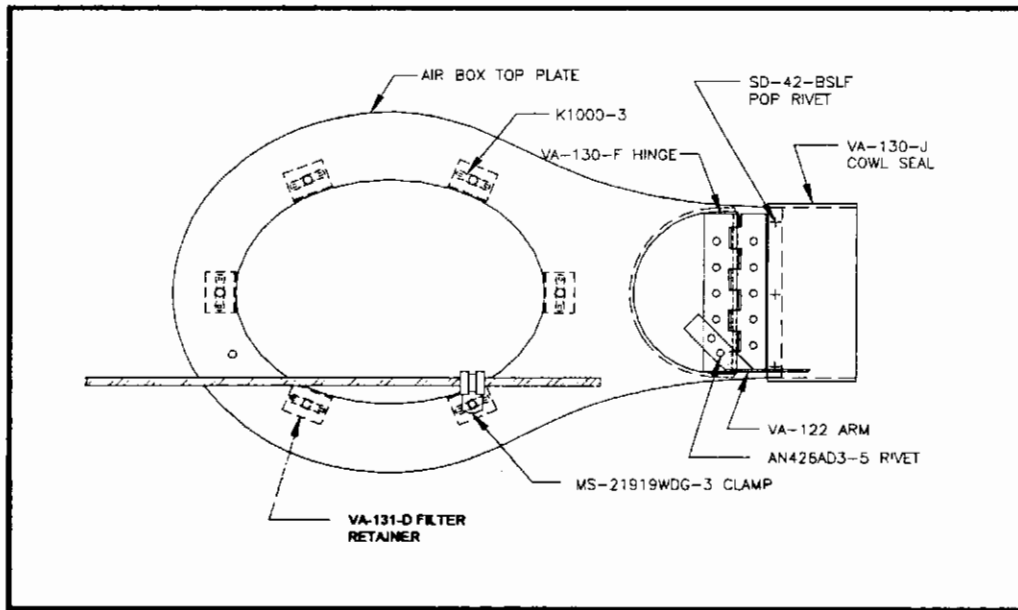
**FIG. 2**



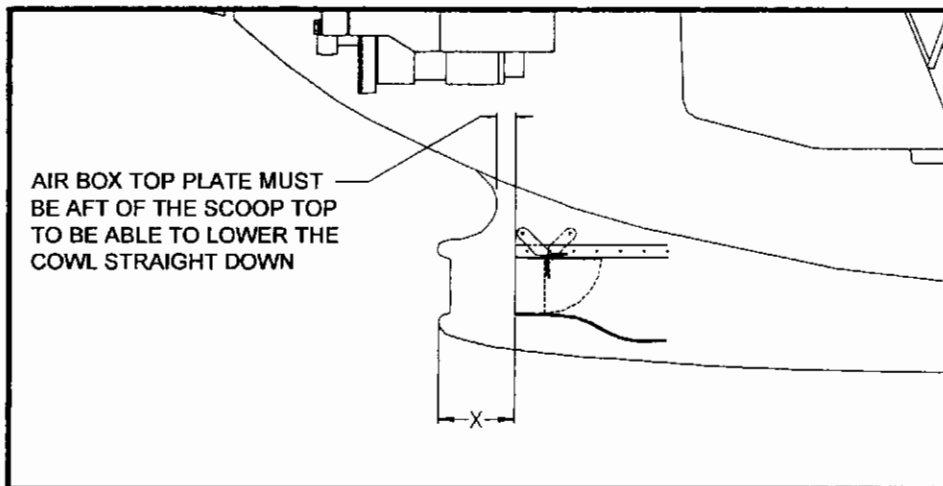
**FIG. 3**



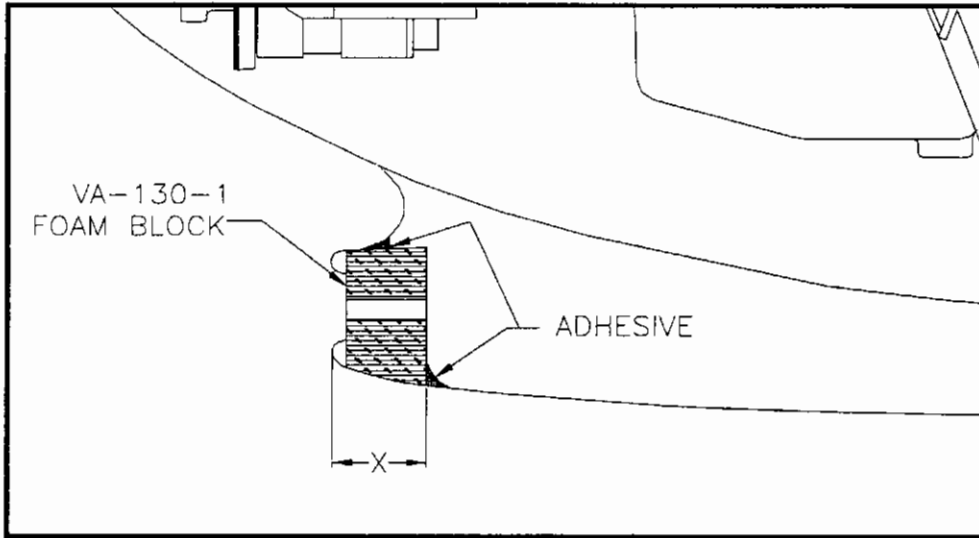
**FIG. 4**



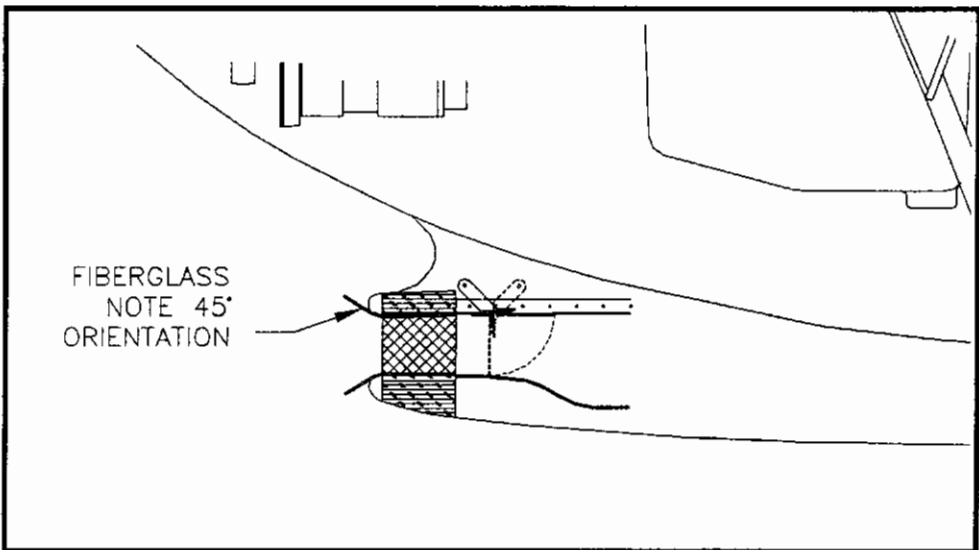
**FIG. 5**



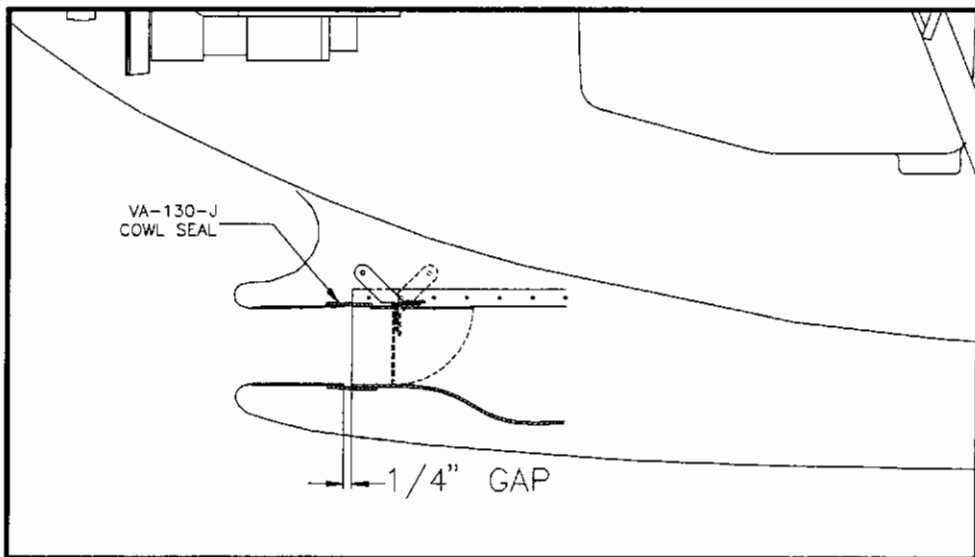
**FIG. 9**



**FIG. 6**



**FIG. 7**



**FIG. 8**

### VA-131-Q INSTALLATION

On engines with a vertical induction fuel injection system the mixture arm will aim downwards for the correct throw direction. The mixture arm will interfere with the left side of the Filtered Airbox Assembly which can be removed by using the VA-131Q Recess.

Trim the flanges of the VA-131Q Recess. Flute the flanges of the recess until the recess matches the shape of VA-131A. Position the recess on the filtered airbox to match the throw of the mixture arm. Mark the recess contour on VA-131A. Cut this area away from the side of VA-131A. With the filtered airbox reassembled mark the recess contour on VA-131B. Cut away this area from VA-131B. Test fit VA-131B to VA-131C and notch VA-131C as required.

Drill #40 the VA-131Q Recess to VA-131A in five places. Drill #40 the recess to VA-131B in four locations (note the fastener that attaches VA-131B to VA-131C). Disassemble and deburr all parts.

Rivet on VA-131Q at the same time VA-131A and B are riveted together.

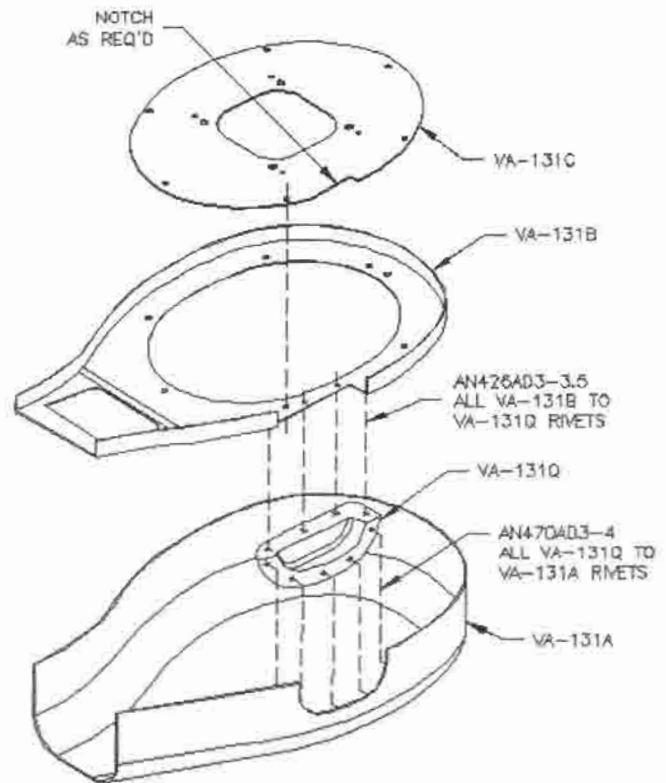


FIGURE 1: EXPLODED ISO VIEW

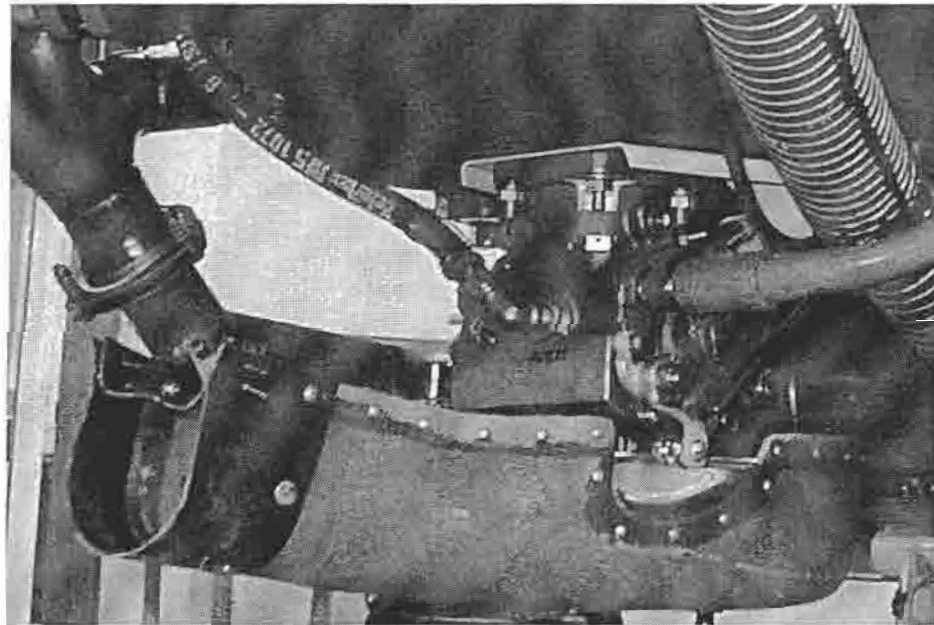
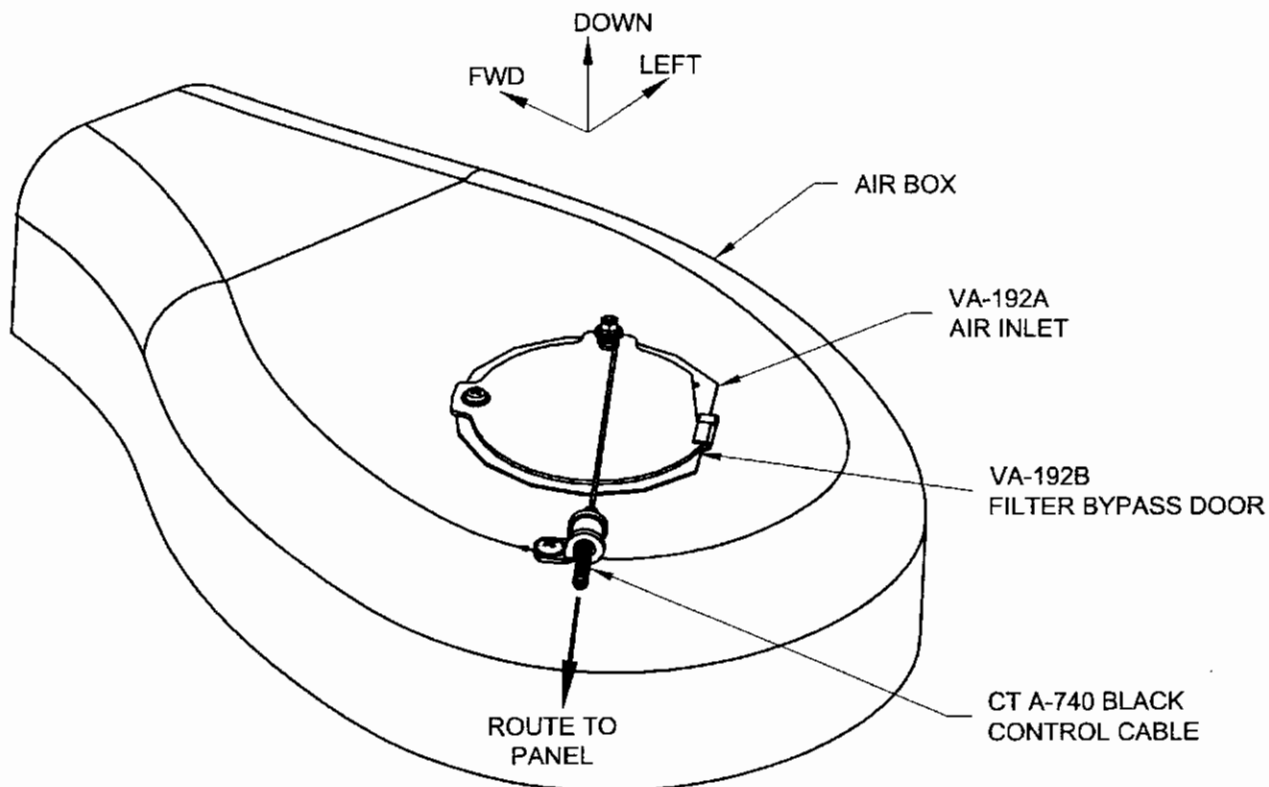


FIGURE 2: FINAL INSTALLATION

# FILTER BYPASS DOOR INSTALLATION

## BILL OF MATERIALS

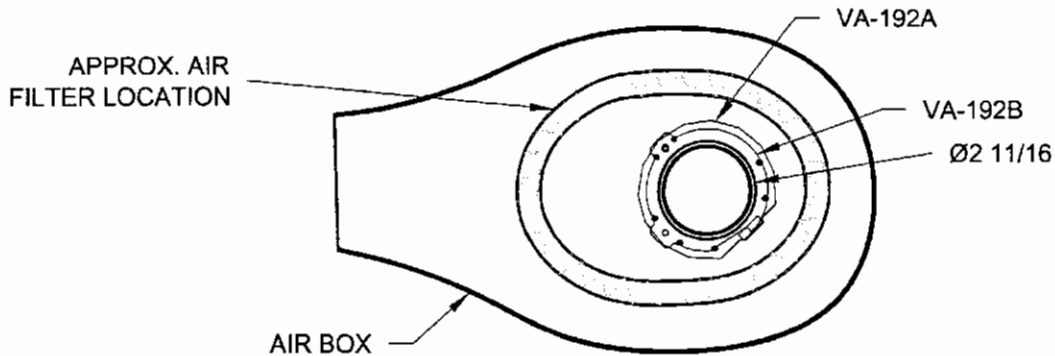
1 5610-18-31	PLASTIC WASHER	1 CT A-740 BLACK	CONTROL CABLE
8 AK-42H	BLIND RIVET	1 K1000-08	NUTPLATE
2 AN426AD3-3.5	RIVET (EXTRA)	1 K1000-3	NUTPLATE
2 AN426AD3-4	RIVET	1 MS21042-08	METAL LOCK NUT
2 AN426AD3-4.5	RIVET	1 MS21919WDG3	ADEL CLAMP
1 AN509-8R8	SCREW	1 VA-192A	AIR INLET
1 AN515-8R8	SCREW	1 VA-192B	FILTER BYPASS DOOR
1 AN525-10R7	WASHER HEAD SCREW	1 DOC BYPASS VERTICAL	
1 AN960-8	WASHER		



**FIGURE 1: OVERVIEW**

**Step 1:** Position the VA-192A Air Inlet on the bottom of the Air Box so that the opening is within the air filter (see Figure 2). Use the VA-192B Filter Bypass Door to check that movement of the door does not create interference with the air box drain, cowl or any other part of the engine installation. Cut a hole per the dimensions in Figure 2 to allow the air inlet to lay flush against the air box.

**Step 2:** Match-Drill #30 the VA-192A Air Inlet to the bottom of the Air Box. Match-Drill #40 the nutplate attach holes in the air inlet to the air box. Match-Drill #19 the screw hole for the nutplate to the air box.



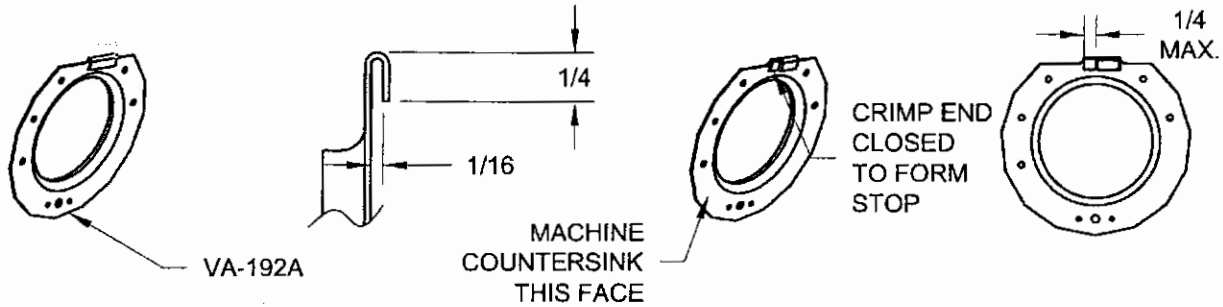
**FIGURE 2: AIR BOX TOP VIEW**



# LATION VERTICAL INDUCTION

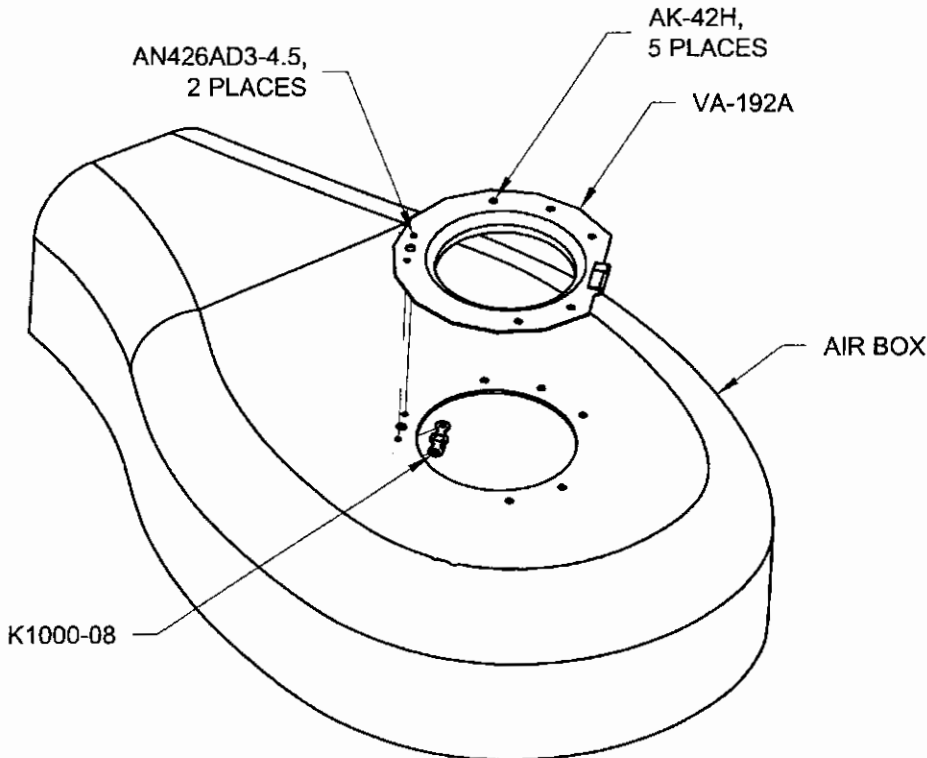
**Step 3:** Machine countersink the two nutplate holes and air inlet attach holes match-drilled in Step 2 (see Figure 3).

**Step 4:** Bend and crimp the tab as shown in Figure 3.

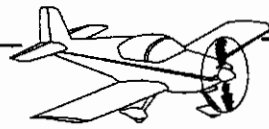


**FIGURE 3: MAKING THE DOOR CATCH**

**Step 5:** Add a layer of fuel tank sealant to the mating face of the VA-192A Air Inlet. Cleco then rivet the air inlet and nutplate to the Air Box per the callouts in Figure 4.



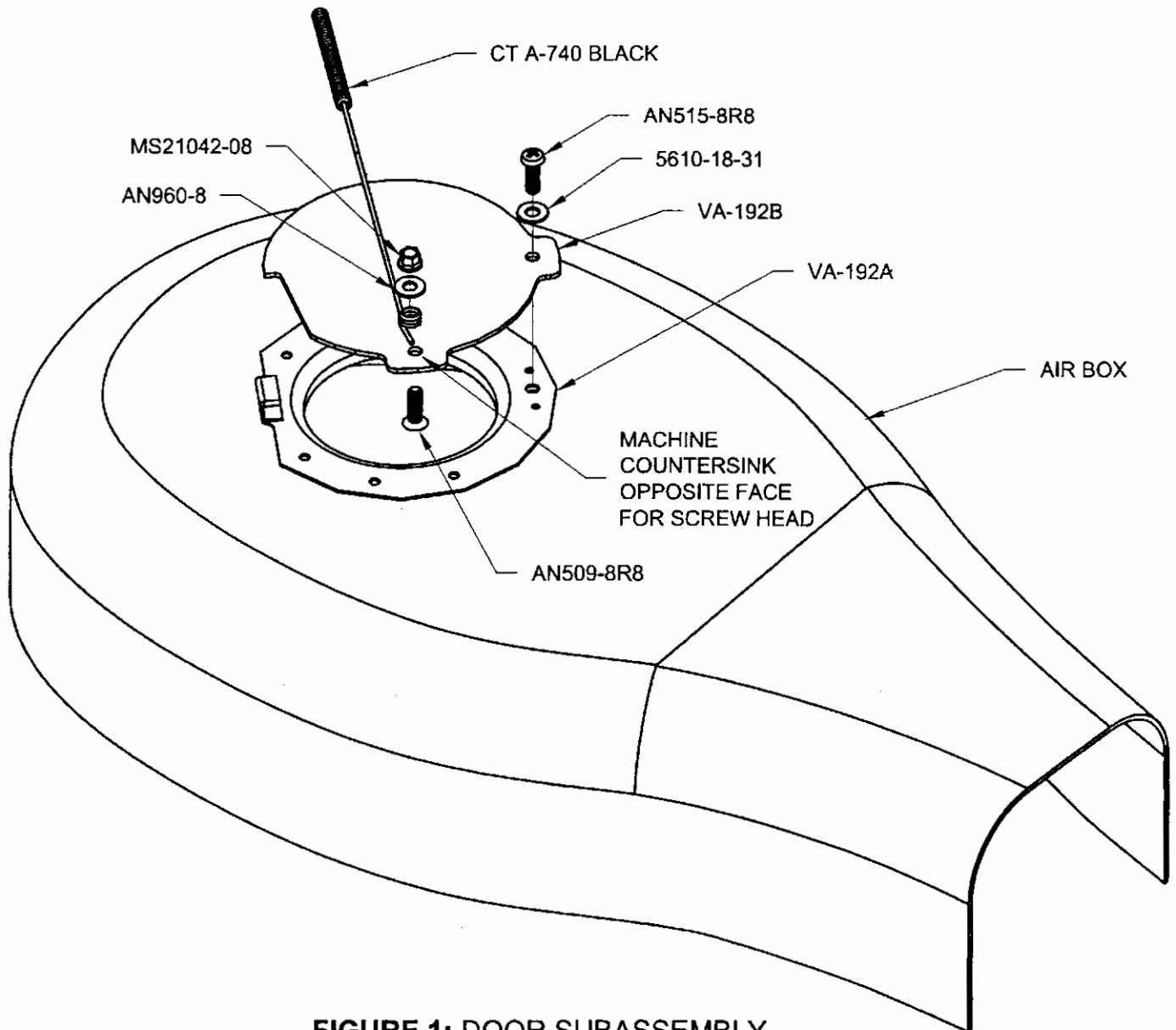
**FIGURE 4: AIR INLET INSTALL**



**Step 1:** Machine countersink the VA-192B Filter Bypass Door to make the head of the AN509-8R8 Screw flush with the indicated face in Figure 1.

**Step 2:** Install a washer and screw to form the hinge axis of the VA-192B Filter Bypass Door as shown in Figure 1. Check that the filter bypass door rotates freely (do not over tighten screw). Check that the filter bypass door engages the door catch without prematurely catching on other possible obstructions - edges. It may be necessary to locally bend up the edge of the door catch to allow the filter bypass door to freely slide underneath.

**Step 3:** Slip the AN509-8R8 Screw through the hole in the VA-192B Filter Bypass Door as shown in Figure 1. Attach the CT A-740 Black Control Cable to the filter bypass door by first wrapping the cable around the AN509-8R8 Screw three times then clamping the cable against the filter bypass door with a washer and nut as shown in Figure 1.



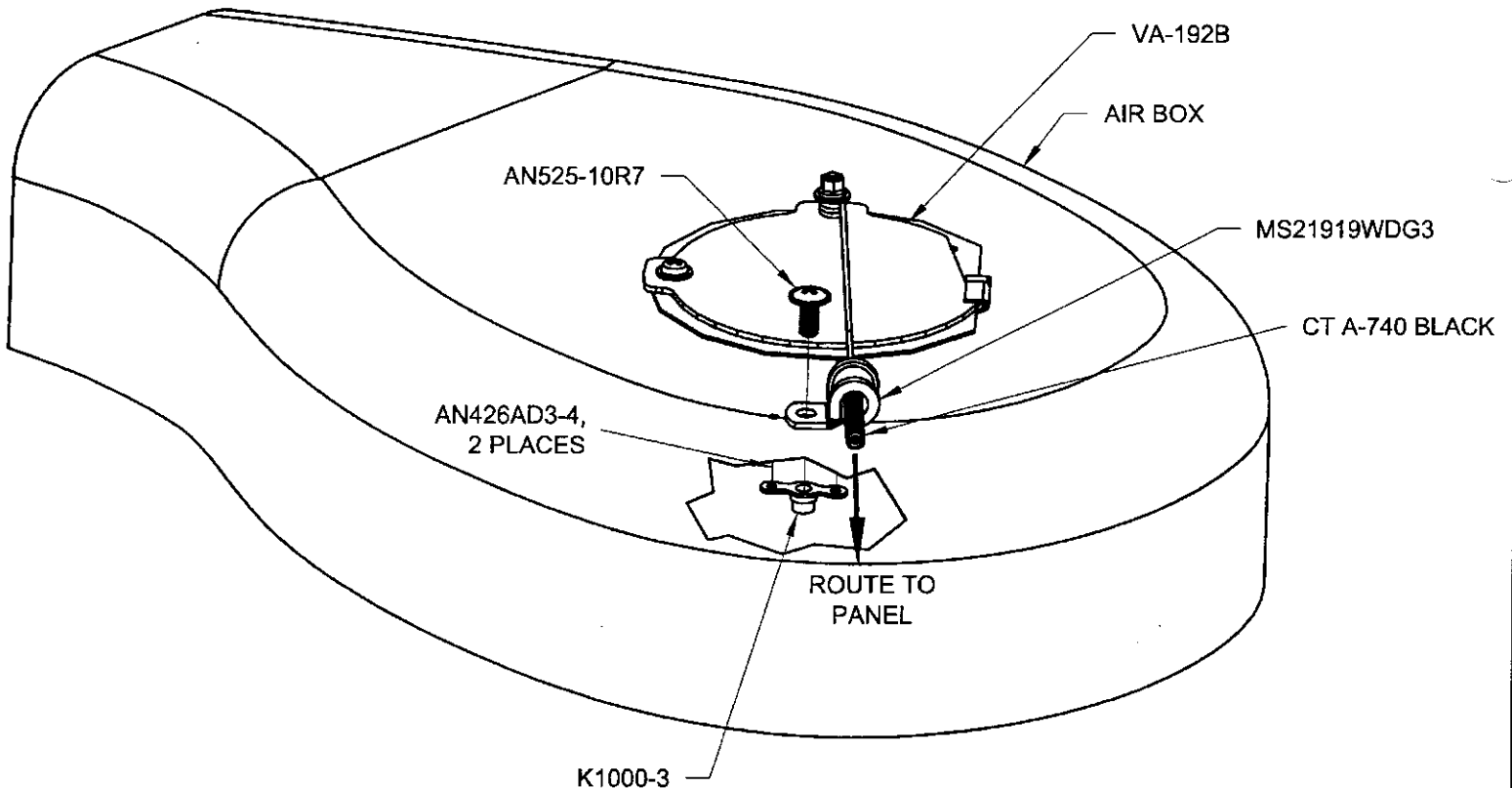
**FIGURE 1: DOOR SUBASSEMBLY**

**Step 4:** Position the CT A-740 Black Control Cable and adel clamp approximately as shown in Figure 2 so that the VA-192B Filter Bypass Door operates freely. Check that the position of the clamp will position the nutplate for the adel clamp outside the perimeter of the filter! Match-Drill #12 the hole in the flange of the adel clamp into the Air Box.

**Step 5:** Attach the K1000-3 Nutplate temporarily to the Air Box with the AN525-10R7 Screw. Using the nutplate as a drill guide match-drill #40 the attach holes into the air box. Machine countersink these holes on the outside face of the air box.

**Step 6:** Attach the nutplate to the Air Box using the rivet callouts given in Figure 2.

**Step 7:** Detach the CT A-740 Black Control Cable from the VA-192B Filter Bypass Door. Route the control cable from the instrument panel to the Air Box. Reattach the control cable to the filter bypass door per Step 3. Fasten the adel clamp to the air box using the hardware shown in Figure 2. Check system for proper operation.



**FIGURE 2: SECURING THE CONTROL CABLE**