

MATCO mfg

5 INCH SERIES WHEEL

With Internal Caliper Brakes

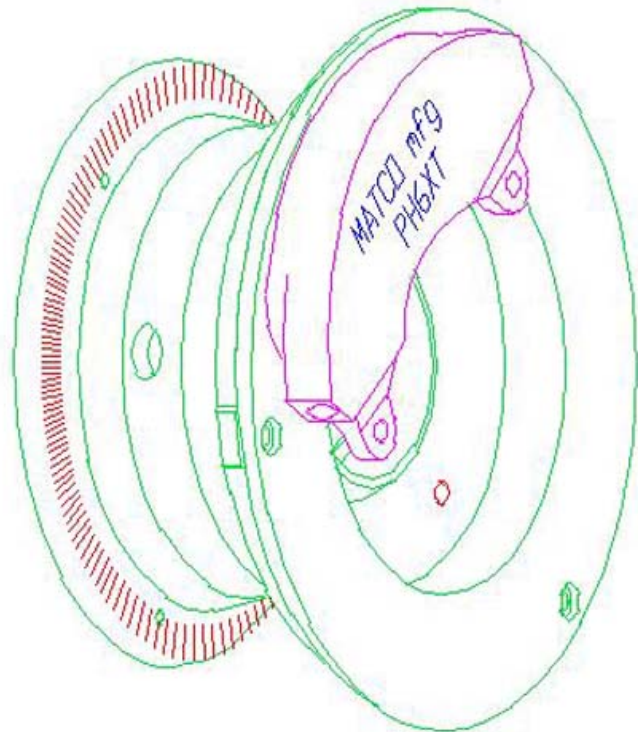

W50L - W50S1.25 - W50LD - W50LT

W50LXT - W50SD - W50ST - W50SXT

W51L - W51LD - W51LT - W51LXT

W51SD - W51ST - W51SXT - W51S1.25

Technical Service Guide

REV 7 03/2011 SRT

Table of Contents

<u>SUBJECT</u>	<u>PAGE</u>
A. 5-Inch Series Wheel & Brake Assembly-----	3
B. 5-Inch Series Brake & Disc Callout-----	5
C. W50 & W51 series Parts List-----	6
D. Brake Assembly Parts List-----	9
E. Brake Assembly Drawings-----	12, 13, 14, 15
F. Brake Lining Wear Limits-----	16
G. Brake Disc Inspection -----	17
H. Brake Lining Installation-----	18
I. Mounting the Tire & Tube-----	19
J. 5" Wheel Assembly -----	19
K. Assembly Torque Values-----	21
L. Caliper Alignment-----	21
M. Bleeding the Brake System-----	23
N. Conditioning Procedures-----	26
O. Maximizing Brake Output-----	27
P. Lubricants-----	34
Q. Technical Assistance-----	35

DRAWINGS & DIAGRAMS

Fig. 1 W50 / 51 Wheel Drawing-----	8
Fig. 2 Single Caliper Single Piston Assembly-----	12
Fig. 3 Dual Caliper Assembly-----	13
Fig. 4 Triple piston 1.25" Assembly-----	14
Fig. 5 Triple Piston XT 1.50"-----	15
Fig. 6 Brake Lining Wear Limits-----	16
Fig. 7 Minimum Disc Thickness-----	18
Fig. 8 Caliper Alignment-----	22
Fig. 9 Pressure Bleeding-----	24
Fig. 10 Vacuum Bleeding-----	25
Dia. 1 Pedal Geometry-----	31
Dia. 2 Pedal Geometry -----	31
Dia. 3 Pedal Geometry -----	32
Dia. 4 Pivot Connect Geometry -----	32
Dia. 5 Heel Brake Geometry -----	33

A. 5 INCH WHEEL & BRAKE ASSEMBLY

DIMENSIONS

The W50L / W51L Series Wheels are a five-inch wheel using an internal caliper design. They have a width of 4.5-inches with additional 1.23-inch caliper spacing. Bearing spacing on the W50S and W51S series wheel is 2.60 inches with an axle spacing of 1.45 inches while bearing spacing on the W50L and standard W51L series wheel is 3.084 inches with an axle spacing of 1.00 inch. The standard bearing axle diameter is 1.25 inches for all wheels in the series and all 5-inch series wheels utilize tapered roller bearings as standard equipment. A ¾ inch (.750) tapered roller bearing is also available for the 5-inch wheels

FEATURES

The 5-inch Series Wheels are centrifugally cast from 535.2 Aluminum alloys for strength, light weight, and a resistance to corrosion that is superior to Magnesium wheels. The 5-inch series wheel uses tapered roller bearings that have been designed and rigorously tested to resist bearing fatigue. This wheel features a five-inch brake assembly available in four configurations for excellent braking performance to match the needs of most aircraft.

Wheel models with the W51 designation use aircraft tires and tubes while those with the W50 designation use industrial tires and tubes.

The 5-inch series wheels utilize one of two axle designs associated with the boss length of the wheel. The long boss wheel ("L" series wheel), utilizes the A1, A1A bolt on axle while the short boss wheel ("S" series wheel), utilizes the A2, A2A bolt on axle. These axles are manufactured using black anodized 2024-T351-T4 alloys. The A1, A1A axles have a bolt hole diameter of 1.946 inches, while the A2, A2A axles have a bolt hole diameter of 2.00 inches

PERFORMANCE

When using the standard 1.25 inch tapered roller bearing, the 5-inch series wheels have a Static Capacity of **1,420 lbs**, and a Load Limit of **4,260 lbs**. When using the .750 tapered roller bearing, the Static Capacity is **1,185 lbs** and the Load Limit is **3,560 lbs**. The following is a list of brake performance standards for each wheel in the series.

W50S1.25, W51S1.25, W50L, W51L

Max Accel/Stop (Kinetic Energy) 189,604 foot-pounds Torque
Rating @ 450psi 1,988 inch pounds

W50SD, W50LD, W51SD, W51LD

Max Accel/Stop(Kinetic Energy) 283,613 foot pounds
Torque Rating @ 450 psi 3,976 inch pounds

W50ST, W50LT, W51ST, W51LT

Max Accel/Stop(Kinetic Energy) 337,932 foot pounds
Torque Rating @ 450 psi 4,266 inch pounds

W50SXT, W50LXT, W51SXT, W51LXT

Max Accel/Stop(Kinetic Energy) 337,932 foot pounds
Toque Rating @ 450 psi 6,143 inch pounds

HOW TO READ MATCO mfg. PART NUMBERS

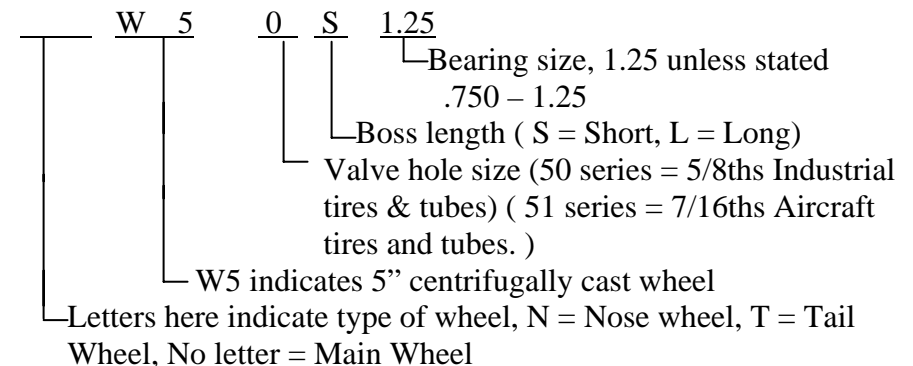

ABBREVIATIONS Used for part number recognition

S = Short	L = Long
SD = Short Dual Piston	LD = Long Dual Piston
ST = Short Triple Piston	LT = Long Triple Piston
SXT = Short eXtra Torque	LXT = Long eXtra Torque

Short and long refer to the boss length on the wheel. The short being 2.6 inches, and the long being 3.084 inches

TIRE & TUBE

Any 500X5 tire and tube combination can be used with the 5 inch series wheels. MATCO mfg. Recommends the Michelin Condor or Airtrac TIRT500X5 6 ply rating tire for the 51 series wheel, and the TIRT1145 8 ply rated tire for the 50 series wheel. Both options supply superior wear and performance.

B. 5 INCH SERIES BRAKES & DISCS

BRAKE ASSEMBLY & DISC CALLOUT

WHEEL	BRAKE ASSY	BRAKE DISC
W50S1.25	WHLB5-4	WHLD5
W50SD	WHLB5-D	WHLD5D
W50ST	WHLB5T	WHLD5T
W50SXT	WHLB5XT	WHLD5T
W50L	WHLB5-5	WHLD5
W50LD	WHLB5-D	WHLD5D
W50LT	WHLB5T	WHLD5T
W50LXT	WHLB5XT	WHLD5T
W51L	WHLB5-5	WHLD5
W51LD	WHLB5-D	WHLD5D
W51LT	WHLB5T	WHLD5T
W51LXT	WHLB5XT	WHLD5T
W51S1.25	WHLB5-4	WHLD5
W51SD	WHLB5-D	WHLD5D
W51ST	WHLB5T	WHLD5T
W51SXT	WHLB5XT	WHLD5T

C. W50 & W51 SERIES PARTS LIST

W50 SERIES PARTS LIST									
Fig 1. Ref #	PART NUMBERS	W50 L	W50 LD	W50 LT	W50 LXT	W50 S1.25	W50 SD	W50 ST	W50 SXT
1	WHLW50/1.25 Valve Half W50/1.25	1	1	1	1	1	1	1	1
2	WHLB50S1.25 Brake Half B50S1.25					1	1	1	1
	WHLB50/1.25 Brake Half WB50L1.25	1	1	1	1				
3	WHLLM6700LA Roller Bearing 1.25"	2	2	2	2	2	2	2	2
4	WHLLM67010 Race 1.25	2	2	2	2	2	2	2	2
5	MSCAN363-428 Flex Lock Nut	3	3	3	3	3	3	3	3
6	MSCAN960-416 Washer	6	6	6	6	6	6	6	6
7	MSCAN4-22A Bolt	3	3	3	3	3	3	3	3
7A	MSCNL1/4 Nordloc Washer	3	3	3	3	3	3	3	3
COUNTERBORE ON DISC MUST BE 0.5" TO USE NL WASHER									
IF 7A NOT USED, #8 TO BE SHCS(A) INSTEAD OF BHCS									
8	MSC.25-20X.62BHCS ButtonHead Cap Screw	3				3			
	MSC.25-20X.75BHCS Button Head CS		3	3	3		3	3	3
BRAKE DISCS									
9	WHLD5	1				1			
	WHLD5D		1				1		
	WHLD5T			1	1			1	1
BRAKE ASSEMBLIES									
See Fig. 2, 3, 4, 5	WHLB5-5	1							
	WHLB5-D		1				1		
	WHLB5T			1				1	
	WHLB5XT				1				1
	WHLB5-4					1			

Fig. 1
W50 / W51 WHEEL DRAWING

W51 SERIES PARTS LIST									
Fig.1 Ref #	PART NUMBERS	W51 L	W51 LD	W51 LT	W51 LXT	W51S 1.25	W51 SD	W51 ST	W51 SXT
1	WHLW51/1.25 Valve Half W511.25	1	1	1	1	1	1	1	1
2	WHLB51S1.25 BrakeHalf B51S1.25					1	1	1	1
	WHLB51/1.25 Brake Half WB50L1.25	1	1	1	1				
3	WHLLM6700LA Roller Bearing 1.25"	2	2	2	2	2	2	2	2
4	WHLLM67010 Race 1.25	2	2	2	2	2	2	2	2
5	MSCAN363-428 Flex Lock Nut	3	3	3	3	3	3	3	3
6	MSCAN960-416 Washer	6	6	6	6	6	6	6	6
7	MSCAN4-22A Bolt	3	3	3	3	3	3	3	3
7A	MSCNL1/4 Nordloc Washer	3	3	3	3	3	3	3	3
COUNTERBORE ON DISC MUST BE 0.5" TO USE NL WASHER									
IF 7A NOT USED, #8 TO BE SHCS(A) INSTEAD OF BHCS									
8	MSC.25-20X.62BHCS ButtonHead Cap Screw	3				3			
	MSC.25-20X.75BHCS ButtonHead Cap Screw		3	3	3		3	3	3
BRAKE DISCS									
9	WHLD5	1				1			
	WHLD5D		1				1		
	WHLD5T			1	1			1	1
BRAKE ASSEMBLIES									
See Fig. 2, 3, 4, 5	WHLB5-5	1							
	WHLB5-D		1				1		
	WHLB5T			1				1	
	WHLB5XT				1				1

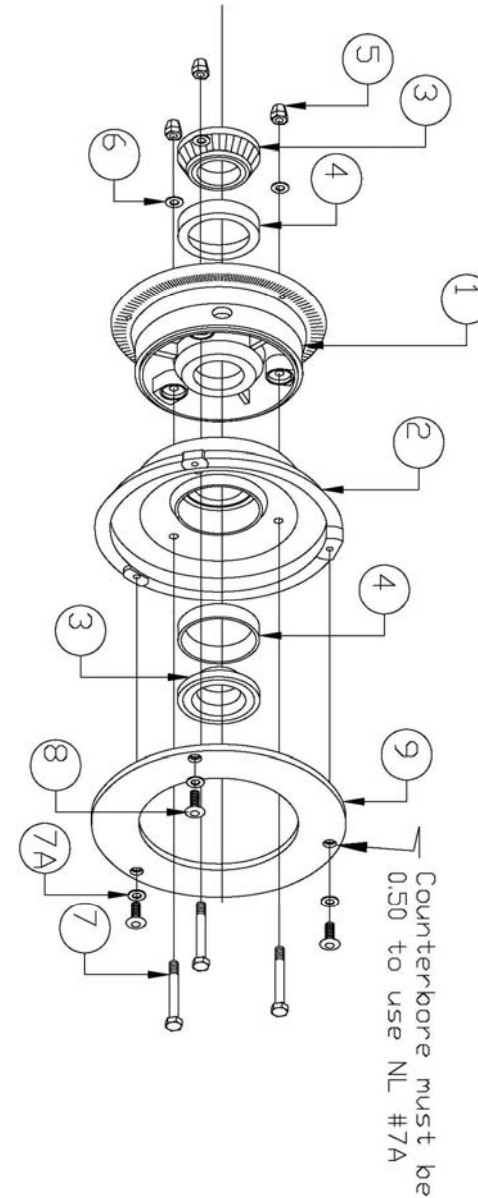

D. BRAKE ASSEMBLY PARTS LIST

WHLB5-5 see Fig. 2

DWG #	PART NUMBER	DESCRIPTION	QUANTITY
1	MSC.25-28 NYLOCK	Nylock Nut	2
2	MSCAN960-416L	Washer	2
3	MSC2X	Cap Plug	1
4	WHLPH-1A	Puck Housing	1
5	MSCBBS(A)	Brake Bleeder Seat	1
6	MSC2-222	O-Ring Buna N	1
7	MSCF6446-007	Brake Bleeder Valve	1
8	WHLPI-1	Piston 1.50"	1
9	MSC.234-X50IL	Dust Plug	1
10	WHLMBS5	Movable Brake Shoe	1
11	WHLM66-106	Brake Lining	2
12	MSC4-6	Brass Rivet	6
13	WHL SBS5	Stationary Brake Shoe	1
14	MSC.25-20X2.00HH	Bolt Hex Head	2
15	WHLBSP5	Spacer	4
16	WHLBPA1.38	Brake Plate 1.38	1
17	MSCAN4-20A	Bolt	2
18	MSCAN960-416L	Washer	2
19	MSCNL1/4	Nordloc Washer	2

WHLB5- 4 See Fig. 2

DWG #	PART NUMBER	DESCRIPTION	QUANTITY
1	MSC.25-28 NYLOCK	Nylock Nut	2
2	MSCAN960-416L	Washer	2
3	MSC2X	Cap Plug	1
4	WHLPH-1A	Puck Housing	1
5	MSCBBS(A)	Brake Bleeder Seat	1
6	MSC2-222	O-Ring Buna N	1
7	MSCF6446-007	Brake Bleeder Valve	1
8	WHLPI-1A	Piston 1.50"	1
9	MSC.234-X50IL	Dust Plug	1
10	WHLMBS5	Movable Brake Shoe	1
11	WHLM66-106	Brake Lining	2
12	MSC4-6	Brass Rivet	6
13	WHL SBS5	Stationary Brake Shoe	1
14	MSC.25-20X2.00HH	Bolt Hex Head	2
15	WHLBSP5	Spacer	4
16	WHLBPA1.25	Brake Plate 1.25	1
17	MSCAN4-20A	Bolt	2
18	MSCAN960-416L	Washer	2
19	MSCNL1/4	Nordloc Washer	2

WHLB5-D see Fig. 3

DWG #	PART NUMBER	DESCRIPTION	QUANTITY
1	MSC.25-20X2.00HH	Hex Head	4
2	MSCAN4-20A	Bolt	4
3	WHL SBS5	Stationary Brake Shoe	2
4	WHLBSP6	Spacer Dual / Triple	8
5	WHLM66-106	Brake Lining 5/6"	4
6	WHLMBS5	Movable Brake Shoe 5/6"	2
7	WHLPI-1	Piston 5/6" 1.50"	2
8	MSCBBS(A)	Brake Bleeder Seat	1
9	MSC.234-X50IL	Dust Plug	1
10	MSCF6446-007	Brake Bleeder Valve	1
11	MSC4-6	Brass Rivet	12
12	WHLBPD1.38	Plate BPD1.38 or BPD2.0 Dual	1
13	MSC2-222	O- Ring Buna N	2
14	WHLPH-1A	Puck Housing	2
15	MSC2X	Cap Plug	3
16	MSCAN960-416L	Washer	4
17	MSC.25-28NYLOCK	Nylock Nut	4
18	MSCAN960-416L	Washer	4
19	MSCNL1/4	Nordloc Washer	2

WHLB5T see Fig. 4

1	MSC.25-28NYLOCK	Nylock Nut	2
2	MSCAN960-416L	Washer	4
3	WHLPH-6	Puck Housing Triple	1
4	MSC2-214	O-ring Buna N	3
5	WHLPI-3	Piston Triple Puck	3
6	MSC2X	Cap Plug	1
7	WHLMBS6	Movable Brake Shoe	1
8	MSC4-4	Brass Rivet	4
9	MSC4-6	Brass Rivet	4
10	WHLM66-105	Lining Triple	4
11	WHL SBS6	Stationary Brake Shoe	1
12	MSC.234-X.50IL	Dust Plug	1
13	MSCF6446-007	Brake Bleeder Valve	1
14	MSCBBS(A)	Brake Bleeder Seat	1
15	WHLBSP6	Spacer Dual/Triple	2
16	WHLBPA1.505T	Brake Plate 1.505T	1
17	MSC.31-18X1.75HH	Bolt, Hex Head	4
18	MSCAN4-20A	Bolt	2
19	WHLBSP600	Spacer W600	4
20	MSCNL8	Nordloc Washer	4

WHLB5XT see Fig. 5			
DWG #	PART NUMBER	DESCRIPTION	QUANTITY
1	MSC.25-28 NYLOCK	Nylock Nut	2
2	MSCAN960-416L	Washer	4
3	WHLPH-6XT	Puck Housing, Triple 1.50"	1
4	MSC2-218	O-Ring Buna N	3
5	WHLPI-3XT	Piston Triple Puck 1.50"	3
6	MSC2X	Cap Plug	1
7	WHLMBS6XT	Movable Brake Shoe	1
8	MSC4-4	Brass Rivet	4
9	MSC4-6	Brass Rivet	4
10	WHLM66-105	Lining Triple	4
11	WHL SBS6	Stationary Brake Shoe	1
12	MSC.234-X50IL	Dust Plug	1
13	MSCF6446-007	Brake Bleeder Valve	1
14	MSCBBS(A)	Brake Bleeder Seat	1
15	WHLBSP6	Spacer Dual / Triple	2
16	WHLBPA1.505T	Brake Plate 1.505T	1
17	MSC.31-18X1.75HH	Bolt, Hex Head	4
18	MSCAN4-20A	Bolt	2
19	WHLBSP600	Spacer W600	2
20	MSCNL8	Nordloc Washer	4
21	WHLBSP600XT	Spacer W600XT	1

E. BRAKE ASSEMBLY DRAWINGS

Fig.2
5 INCH SERIES WHLB5-5 & WHLB5-4
SINGLE CALIPER 1.50" SINGLE PISTON

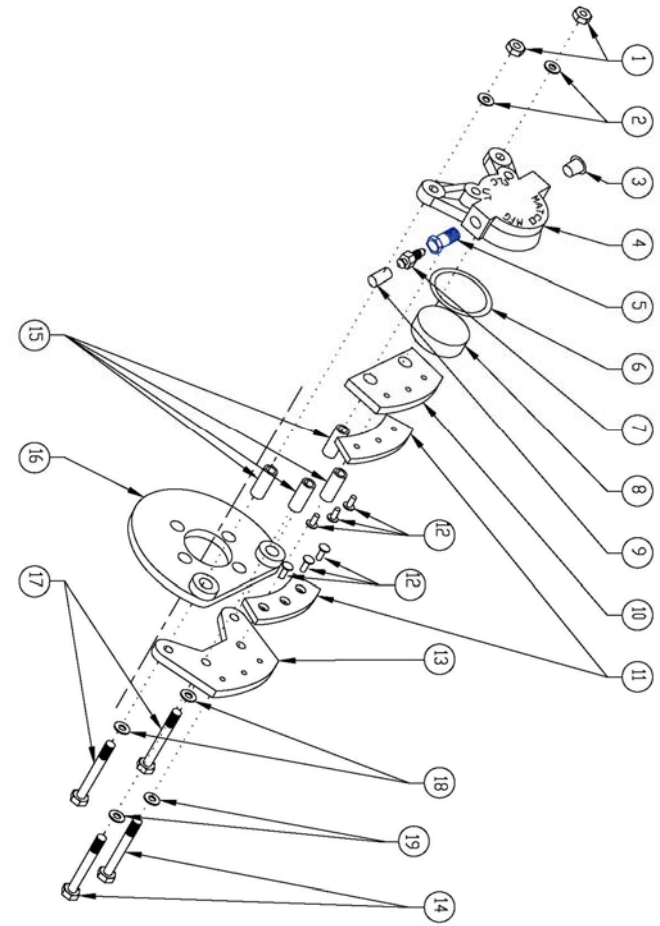

Fig.3
5 INCH SERIES WHLB5-D
DUAL CALIPER ASSEMBLY 1.50"

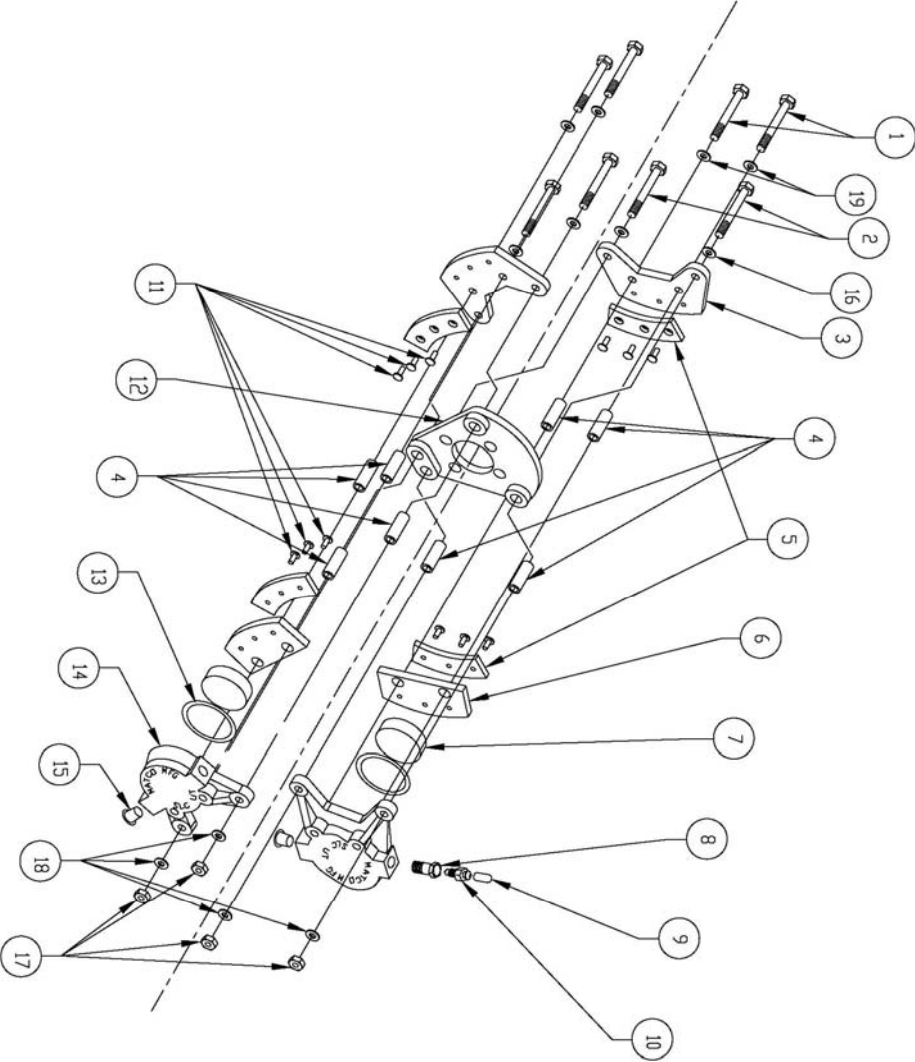

Fig. 4
5-INCH SERIES WHLB5T
TRIPLE PISTON 1.25"

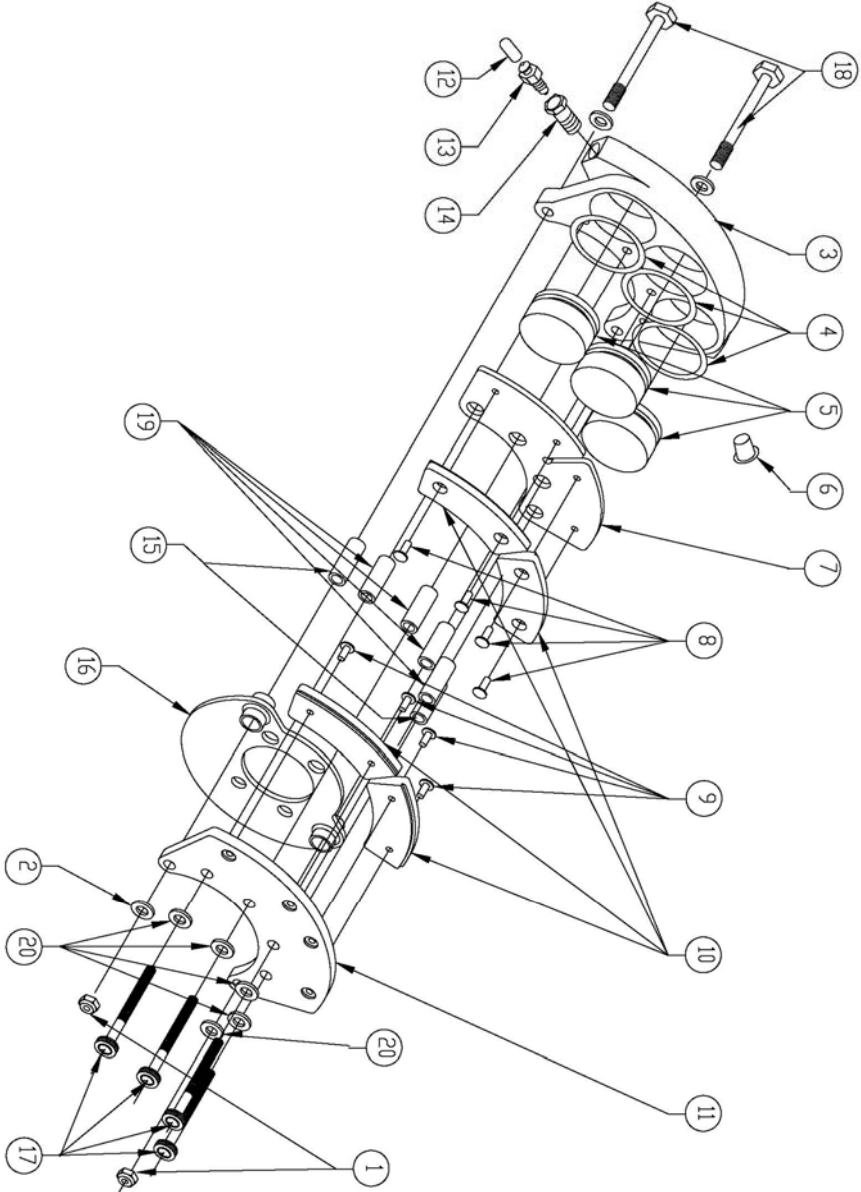
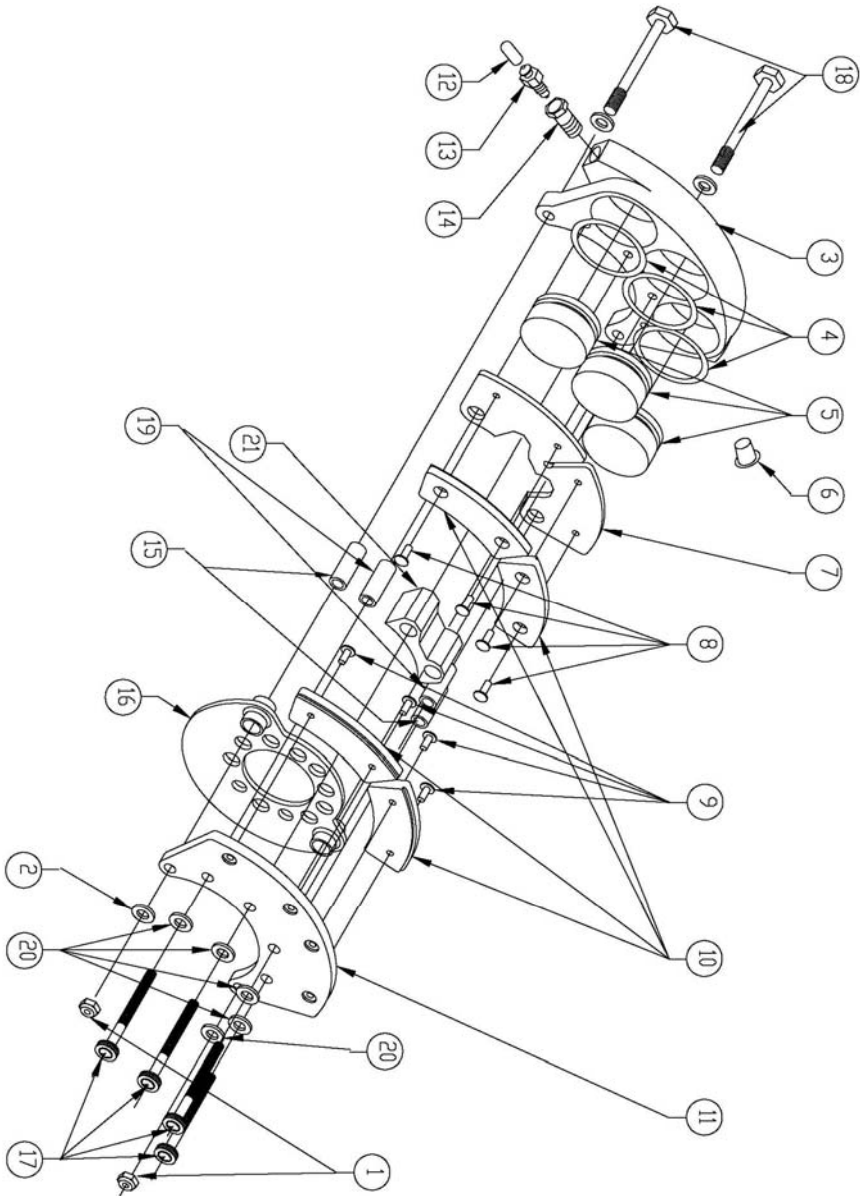

Fig. 5
**5-INCH SERIES WHLB5XT
 TRIPLE PISTON, EXTRA TORQUE**



F. BRAKE LINING WEAR LIMITS

To eliminate wear on brake linings beyond design limitation and reduce possible piston damage or fluid leakage, the following information is presented. The 5 inch series lining should be replaced when the thickness of the remaining wear material reaches 0.100 IN. (2.54mm) See Fig. 6. The WHLM66-105 lining has a Visible Wear Notch located on the side of the lining, and the WHLM66-106 is located on the side. The inside edge of the notch indicates min-material condition.

**Fig. 6
 Break lining wear limits**

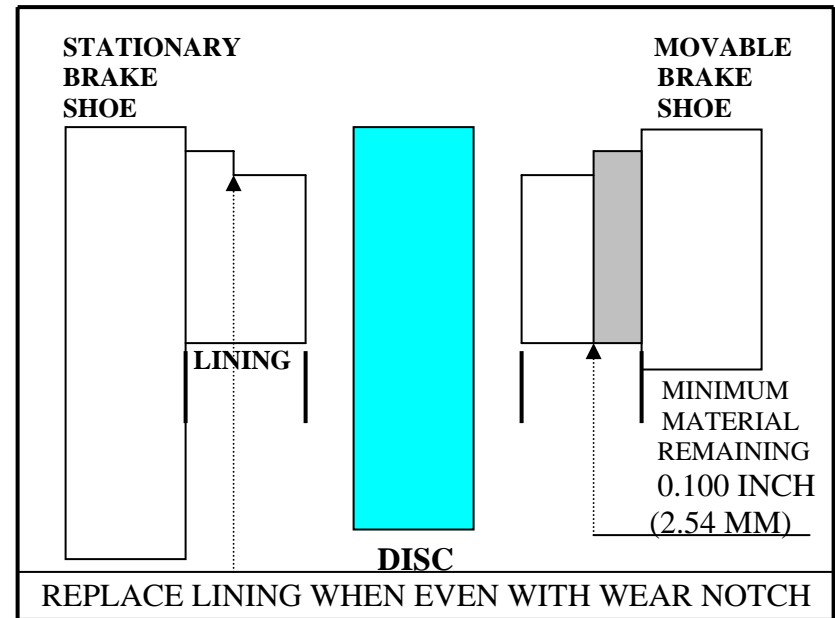

SwiftLine Pad Replacement Program for the W50 & W51

The *Swiftline* Pad Replacement program is designed to:

- Simplify pad replacement on MATCO mfg brakes
- Eliminate the need to rivet linings, saving maint. & tooling.
- Provide a 20 % discount on reline kits saving you money

For more information on Swiftline call 801-355-0582

G. BRAKE DISC INSPECTION

The MATCO brake disc will give years of trouble free service under normal field conditions. Conditions such as unimproved fields, standing water, industrial pollution, or frequent use of the aircraft may require more frequent inspection of the brake system including the disc in order to prolong the life of the brake linings. The disc should be checked for wear (See **Fig. 7 Dim. "A"**) and for any grooves, deep scratches, excessive pitting or coning of the brake disc. Although coning is rarely a problem with the MATCO disc, if it should occur, coning beyond 0.015 inch (0.381mm) in either direction is cause for disc replacement. Isolated grooves up to .030 inch (0.76mm) deep should not be cause for replacement. Any grooving of the disk however, will reduce the service life of the linings.

The WHLD5, WHLD5D and WHLD5T discs are plated for rust prevention. Within a few landings, the plating will wear off where the linings rub against the disc. The remaining portion of the disc will remain plated and corrosion free for an extended period of time under normal use. El-Ni plated discs are available from MATCO for those demanding increased corrosion protection and wear.

Rust in varying degrees may form on the exposed portion of the disc. If powdered rust appears on the surface, one or two braking applications during taxi should wipe the disc clear. Build up beyond this point, may require removal of the disc from the wheel to properly clean both surfaces. Wire brushing followed by cleaning with a 220-grit garnet paper should restore the braking surface adequately. Care should be taken to prevent removal of plating in areas that are not contacted by the lining.

Fig. 7

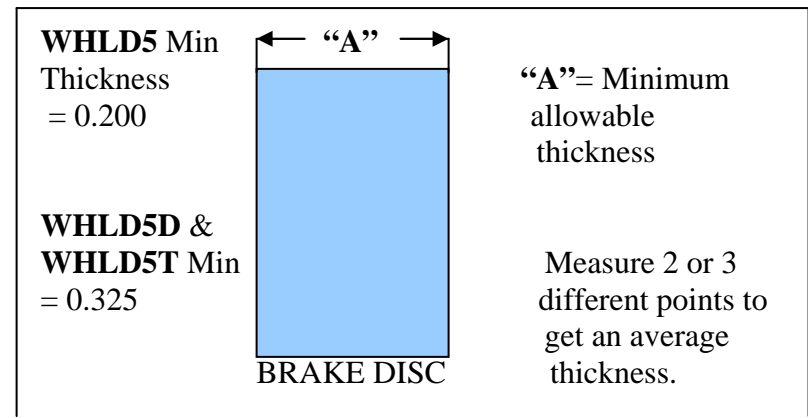

H. BRAKE LINING INSTALLATION

The following instructions offer a guide for properly removing and replacing the WHLM66-105 and the WHLM66-106 brake linings.

1. Release the disc from the wheel by removing the 3 attach bolts. The wheel can be removed to expose the caliper. Remove the caliper from the brake plate by removing the two MSCAN4-20A bolts that hold it on.
(DO NOT DISCONNECT HYDRAULIC LINE)
2. Remove old linings by drilling the crimped side of the rivet (Do not use a punch & hammer). Using a #25 drill (0.1495 diameter), drill through rivet taking care to avoid damaging the rivet hole. After drilling crimped edge off rivets, lift old lining and remaining rivet pieces from the brake shoe.
3. Inspect the brake shoe for any bending or other damage that may have occurred during service. A shoe with more than 0.010 bend should be replaced. Inspect rivet holes to ensure that no damage has occurred during removal.
4. Using a brake relining tool (*MATCO recommends a Threaded Screw Action such as the W404 from Aircraft Tool SupplyCo.*) or pneumatic press, replace the lining using the brass rivets shown on the illustrated parts list.

I. MOUNTING THE TIRE & TUBE

Care should be taken to avoid pinching the tube between the wheel halves when mounting the tire and tube. To avoid this, slightly inflate tube after placing it in the tire. Tire mounting soap may also help. A thin strip of cardboard or poster paper wrapped around the wheel between the mounting half and the tube will help in preventing the tube from being pinched during assembly if it is unusually tight. A preferred method is to use 3 ratcheting bar clamps evenly spaced around the tire and tube to compress the tire. Compress sufficiently to allow the wheel halves to be seated against each other at the shiplap without contacting the tire. The tube can be visibly inspected. Note that on 5.00-5 tubes that the stem nut rides in the slot between the wheel halves and is not designed to be tightened up against the inside of the wheel. It only acts as a guide in centering the tube.

J. 5 INCH WHEEL ASSEMBLY

5" WHEEL ASSEMBLY INSTRUCTIONS

1. The tapered roller bearings should be packed with suitable grease. (*See Section "P" for lubricants*).

IMPORTANT NOTE: Axle Nut Torque

Your MATCO Mfg. wheel is equipped with Timken style tapered roller bearings with integral grease seals on the bearing cone to ensure the longest possible life. Torque procedures for bearings with this type of seal are different than for bearings without them. A common torque method for bearings without seals is to tighten the axle nut until the wheel stops spinning freely then back off to the nearest locking feature. **THIS TECHNIQUE DOES NOT WORK ON BEARINGS WITH AN INTEGRAL SEAL.**

The reason for using a different technique lies in the grease seal which under normal circumstances, produces some drag and

makes the wheel feel somewhat stiff when rotated. Reducing the axle nut torque until the wheel spins freely will allow the grease seal and the bearing cone to rotate improperly with the wheel. **THE CONE MUST NOT ROTATE RELATIVE TO THE AXLE.** The higher rolling drag is completely normal for this bearing and allows for longer bearing life since the seal will keep most contaminants out.

Timken specifications state that the two 1.25 inch tapered roller bearings used on the 5" wheel, produce 8-10 inch pounds of torque (*drag*) when properly installed. A light coating of grease on the seal will help reduce the drag on initial installation. The drag will also reduce after the bearings have been installed and the seal relaxes in the bore. It is important that the axle nut torque be sufficient to keep the seal from rotating with the wheel. The following technique will ensure the longest possible bearing life.

- 2 Tightened the axle nut until all play is out of the assembly. Rotate the wheel back and forth while tightening the nut to help seat the bearings. When all play is out and the wheel rotates freely, tighten to the next slot and insert cotter pin.
- 3 The rubber seal on the tapered roller bearing should remain stationary while the wheel rotates around it. If the seal is spinning on the axle, tighten the nut further until the seal stops spinning with the wheel. (*See Note Above*).
- 4 When using MATCO mfg flanged axles, they can be shimmed for toe-in / toe-out conditions or spaced out from the wheel if necessary for the brake disc attachment screws to clear the landing gear leg.

NOTE: All o-rings in the brake and master cylinder, are Buna Nitrile and are **NOT** compatible with automotive glycol based brake fluids such as DOT 3, DOT 4, and DOT 5.1

IMPORTANT NOTICE USE ONLY red aircraft fluid (Mil-H-5606 or equivalent) brake fluid.

K. ASSEMBLY TORQUE VALUES

FIG. #	ITEM #	PART NUMBER	TORQUE VALUE INCH POUNDS
1	7	MSCAN4-22A	99 IN-LB
1	7A	MSC.25-20X.62 OR .75BHCS	100 IN-LBS (90 IN-LB FOR SHCS)
2	14	MSC.25-20X2.00HH	100 INCH POUNDS
3	1		
2	17	MSCAN4-20A	50 INCH POUNDS
3	2		
4	18	MSCAN4-20A	50 INCH POUNDS
4	17	MSC.31-18X1.75HH	120 INCH POUNDS
5	5		

L. CALIPER ALIGNMENT

Caliper alignment is determined by measuring the maximum exposed spacer length, as measured on with new disc & linings. (See **Fig. 8**)

1. Maximum exposed length should be 0.125 inches.
2. Minimum exposed length should be 0.05 inches
3. Adjust the length by moving the brake plate inboard or outboard as needed to reach proper measurement. (often done using an axle spacer)
4. Note that this measurement applies to both single and triple piston calipers.

Fig. 8

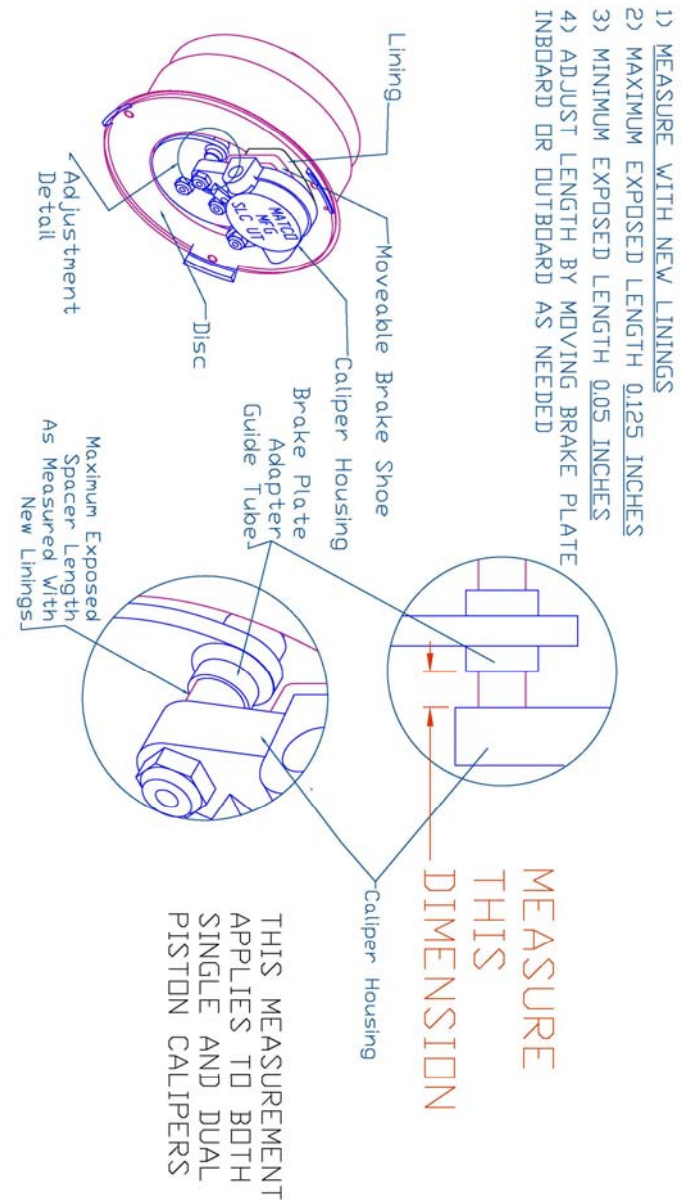

M. BLEEDING THE BRAKE SYSTEM

(SEE FIGURES 9 & 10)

1. Open brake bleeder valve slightly (**Fig. 2 # 7**) (**Fig.3 # 10**). (**Fig.4 # 13**) and (**Fig.5 # 13**) to facilitate bleeding of air from the system.
2. Attach a tube from the nozzle of a bleeder can of brake fluid, to the top of the brake bleeder valve. Pump the handle until oil flows bubble free from service hose before attaching.
3. Make sure that the master cylinder shaft is fully extended to open up the internal bypass valve.
4. Inject brake fluid (Mil-H-5606 or equivalent), into the caliper housing and continue injecting until the fluid travels through the system in to the master cylinder.
5. Air in the system will be pushed up and out in to the master cylinder ONLY IF the master cylinder or remote reservoir is at the highest point in the system, and there are no loops in the brake lines.
6. Fluid should be pushed through the system until it reaches approximately $\frac{1}{4}$ inch from the top of the master cylinder or remote reservoir
7. Close the brake bleeder valve, and remove the service hose.
8. If the brake system is free of air, the brake pedal should feel firm and not spongy. If not, repeat steps 1 through 7 until system is free of trapped air.
9. Fluid leakage from the top of the MCMC-5 / 5A master cylinder during operation indicates too high a fluid level.

NOTE The MCMC-5/5A are NOT approved for inverted flight.

Fig. 9

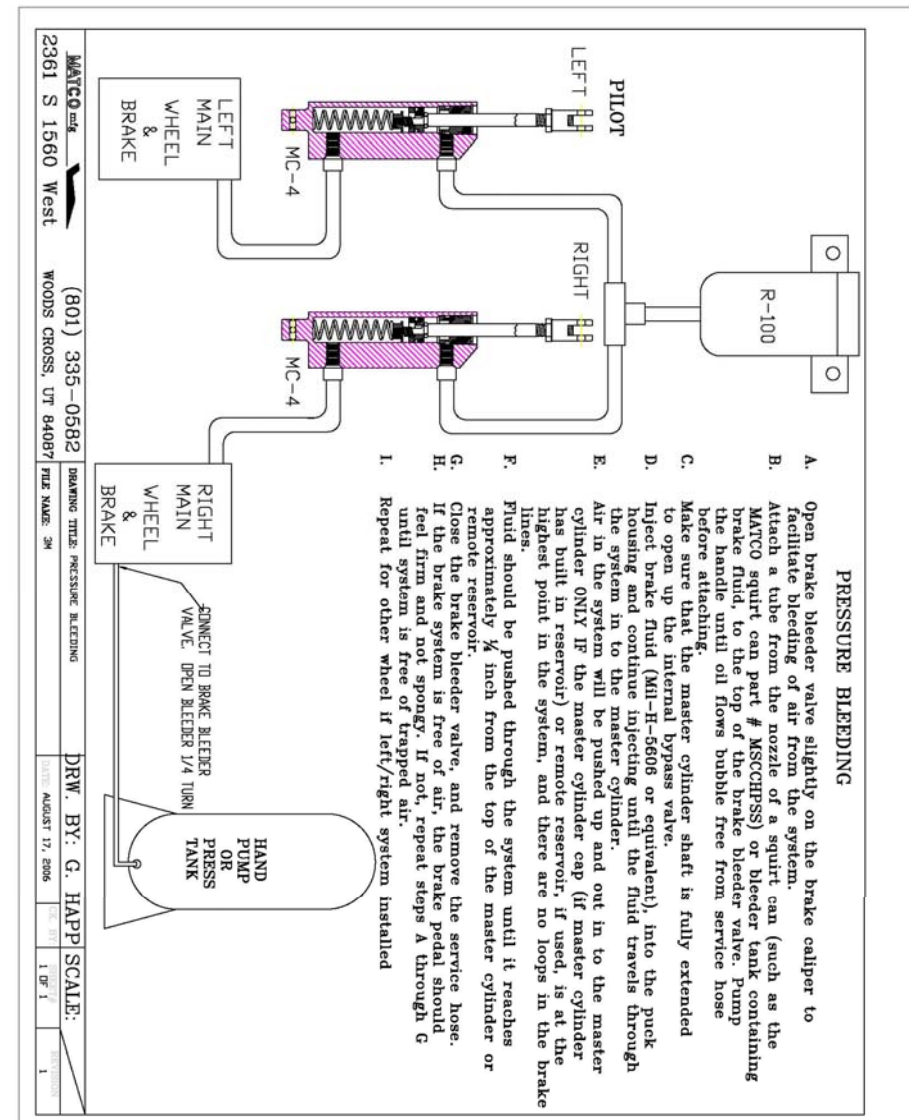

N. CONDITIONING PROCEDURES

NOTE It is important to condition the new linings after installation to obtain maximum service life and performance. The procedures below show when and how this should be done.

1. After the linings have been installed, apply brake pressure during high throttle static run-up. Note RPM at creep if any occurs.
2. Perform two or three high speed taxi runs 30-40 mph and apply firm braking down to 5 mph to generate the necessary 300 – 400 degrees at brake pads. **DO NOT** bring the aircraft to a complete stop during taxi runs, and continue to roll aircraft until reaching the tie down area. Allow brakes to cool 10-15 minutes.
3. Repeat step one and note RPM at creep if any occurs. There should be a noticeable increase in holding torque.
4. If properly conditioned, the pads will have a uniform shiny appearance (*glaze*) on the surface. Repeat steps 1-3 if necessary to produce glaze.

NOTE Forward movement of the aircraft during static runup could be caused by the wheels skidding and not brake malfunction. Use caution when braking heavy on aircraft with a tail-wheel as it could cause the tail to lift from the ground.

Conditioning removes high spots, and creates a layer of glazed material at the lining surface. Normal braking will produce enough heat to maintain glazing during the life of the lining. Glazing can be worn off during light use such as taxiing.

Fig. 10

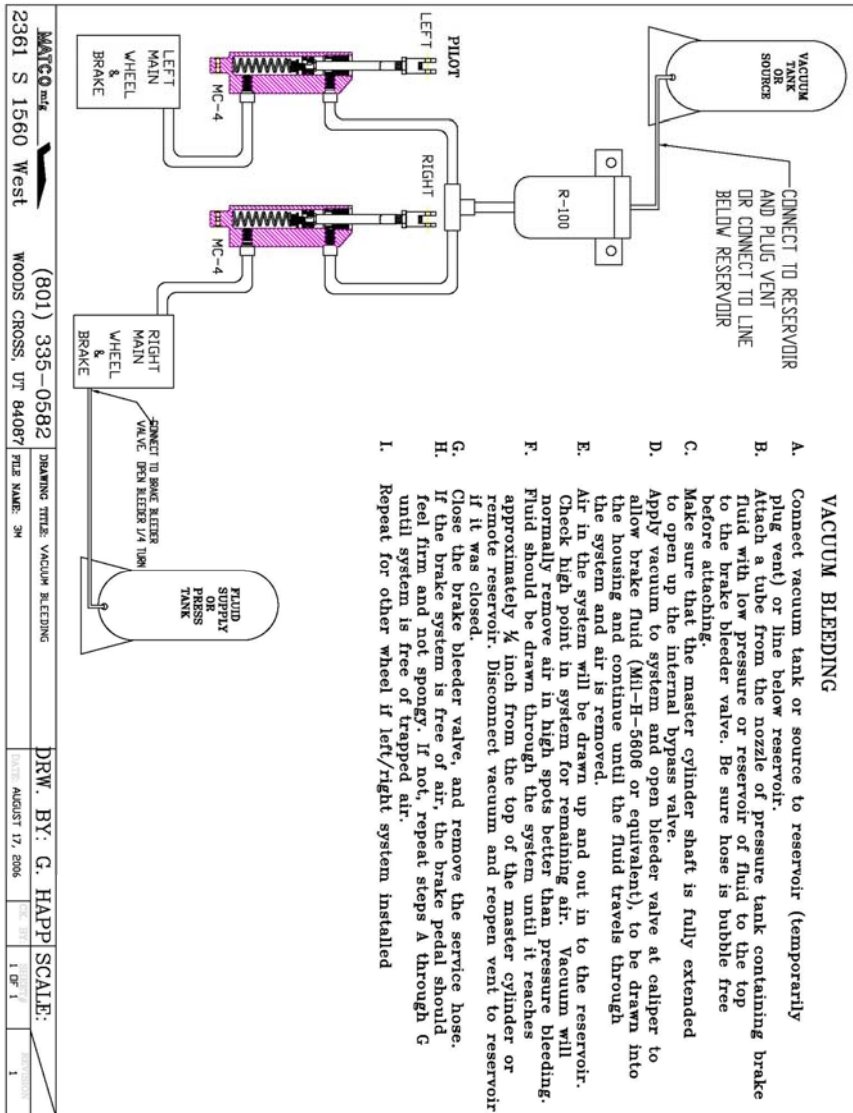

O. MAXIMIZING BRAKE OUTPUT

GETTING YOUR PEDAL GEOMETRY RIGHT

BRAKE SPECIFICATIONS

All MATCO mfg. brakes have two specified ratings. The first is the energy rating which specifies the energy capacity of the brake. This value is used in selecting a brake that will be able to absorb the kinetic energy of the aircraft under the designers specified maximum energy condition (*generally maximum aircraft weight at a velocity above stall speed*). The energy rating is determined by the disc weight. Exceeding the energy capacity of a braking system leads to excessive disc temperatures. This can cause low friction coefficients and reduce brake torque and aircraft deceleration. Permanent damage to the disc can result in the form of warping or loss of corrosion protection.

BRAKE TORQUE

The second rating is for brake torque. The rated torque value is used to determine the deceleration and static torque for engine run-up that will be provided by the brake. A braking system using the same disc can have one energy rating and several torque ratings. This is possible by using different caliper configurations on the same disc. For example a braking system using a single caliper on a disc with a 189K ft-lb rating may have a torque rating of 1980 in-lb. The same braking system using two calipers would have the same energy rating of 189K ft-lb but would have a torque rating of 3960 in-lb. MATCO mfg. offers its customers a wide range of caliper configurations and disc sizes to allow for meeting both the energy and torque requirements of their aircraft. (*Look under Features on page 3 for more information on caliper options*).

GETTING THE RATED TORQUE

The rated torque value assumes a nominally conditioned brake pad (*see pad conditioning procedures section 'N'*), rated pressure applied to the brake, free floating calipers, and pad contact on both sides of the disc. Brake pad conditioning allows a glaze to form on the pads and provides the highest friction coefficient and drag force. MATCO mfg. Brake torque ratings are based on 450 psi applied pressure. Pressures below this value will generate proportionally lower torque. Pressures above this value will provide higher torque although pressures above 600 psi generally cause caliper deflections that reduce the torque increase. The torque rating assumes that all caliper force is used to squeeze the brake pads against the disc. If the caliper does not float freely, it is possible that only one side of the disc surface may be contacted resulting in 50% loss of torque.

GET THE PRESSURE RIGHT

Assuming the calipers are properly mounted so that the pads make contact on both sides of the disc (both new and worn) and are maintained so that the calipers float freely, the most common reason for under performance of the brakes is low pressure. MATCO mfg. Brakes need 450 psi to achieve their rated torque. Additional calipers can be added to get higher torque at lower pressures, but is often more weight efficient to modify the hydraulic system pedal geometry to generate higher pressures. Systems using hand or foot operated master cylinders require a minimum of 2.5 to 1 mechanical advantage when using master cylinder, MC, like the MC-4 or MC-5 which have .625 inch diameter pistons. (*Systems using MC-4 or MC-5 with intensifiers have .500-inch pistons and require a 1.6 to 1 mechanical advantage*). Mechanical advantage, MA, is the ratio of the force applied to the master cylinder shaft divided by the force applied by the hand or foot. **Di.1** shows two examples of pedal geometry. The first has an MA of 1 to 1 since the distance from the applied load to the pivot point is the same as the distance to the MC and is undesirable.

The second shows a more favorable configuration that will easily provide the required pressure to the brakes with moderate toe force

It is often necessary to keep the foot pedal shorter than that shown in **Dia.1**. An alternate geometry is shown in **Dia.2**. This design would utilize a fork arrangement on the MC connection to allow clearance of the MC body and then a short linkage to the MC connect point. A design common to many aircraft uses linkage as shown in **Dia.3**. This design also allows for a shorter brake pedal but has a major disadvantage. This linkage can be configured to have a proper MA in the start position (with the master cylinder fully extended). The MA varies with rotation however, as shown in **Fig.2** of **Dia.3**, a 15 degree rotation of the linkage reduces the MA at the start position from 1.5 to 1 down to only 1.12 to 1. In actual operation, this has the effect of causing a nearly constant brake torque even though increasing force is applied. For example, if the geometry is set for an initial MA 2.5 to 1. In the start position and the pilot applies pedal force, the MC will begin to stroke as pressure builds. As the rotation occurs, the MA decreases. If there is any air in the brake lines or if there are long brake line runs, hydraulic system expansion will occur as pressure increases requiring more MC stroke. If the pilot applies more pedal force, more MC stroke occurs, and the MA decreases further. Even though the pilot has now increased his pedal force, the force applied to the MC will be only marginally increased because more rotation will result and cause a further decrease in MA. A geometry like that in **Dia.2** will provide the same reduced pedal height and is not prone to the effect of rotation since the MC is essentially connected to the brake pedal pivot. **Dia.4** illustrates the benefit of pivot connect geometry during rotation. The MA remains virtually unchanged for expected rotation angles and results in a linear pressure increase with applied pedal force.

HEEL BRAKES

A common means of providing pilots with differential braking ability without resorting to a more complicated geometry of toe brakes is to use heel brakes. The same design requirements exist for the MA of a system using heel brakes as for toe brakes. It is not uncommon to see MC's configured to allow the pilot to apply heel force directly to the MC by means of a pad or button connected on the end of the shaft.

This configuration is shown in **Fig.1** of **Dia.5**. The MA of this system is 1 to 1 and produces very low pressure for reasonable heel

force. Perhaps a larger concern however is the potential for causing damage to the MC. The MC is designed to accept loads applied along the length of the shaft. Loads applied off axis or perpendicular to the shaft cause bending moments in the MC shaft that it is not designed for. Damage to the MC end gland, or bending of the MC shaft may result if the off axis loads are high enough. A more desirable configuration for heel brakes is shown in **Fig.2** of **Dia.5**. This system uses a short linkage connected to the MC that provides the 2.5 to 1 MA while insuring that loads will be applied along the length on the MC and prevent any damage during actuation.

CONCLUSION

Like any system on an aircraft, the hydraulic system has many engineering options for providing the necessary requirements. The systems common on light aircraft must be engineered to provide adequate pressure to the brakes to achieve the rated torque.

<p>NOTE MATCO mfg. Brakes require 450 psi to achieve Their rated torque.</p>

The pedal geometry whether hand, toe, or heel operated, requires a mechanical advantage of at least 2.5 to 1. This allows the pilot to easily generate the required 450-psi with moderate applied force. Pivot connected geometry provides the best means of accomplishing this requirement without the problem of rotational effect that reduces mechanical advantage.

PEDAL GEOMETRY / POOR & MINIMUM

Dia. 1 Figures 1 & 2

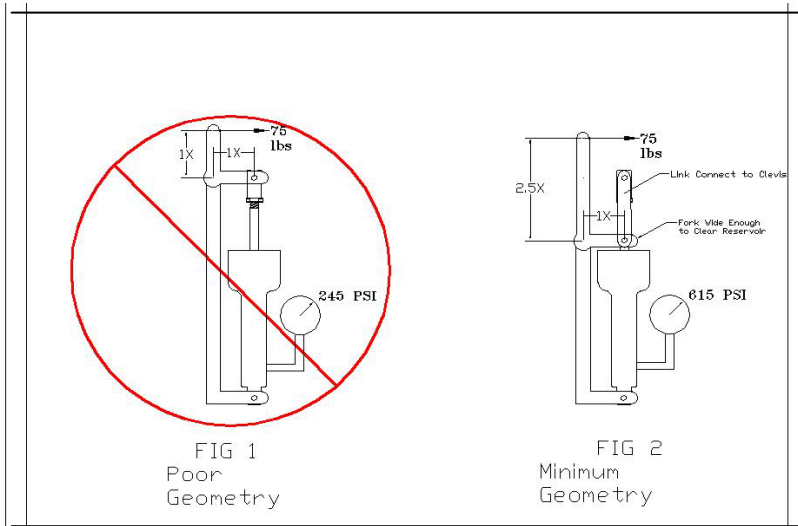

PEDAL GEOMETRY / MECHANICAL ADVANTAGE

Dia. 3 Figures 1 & 2

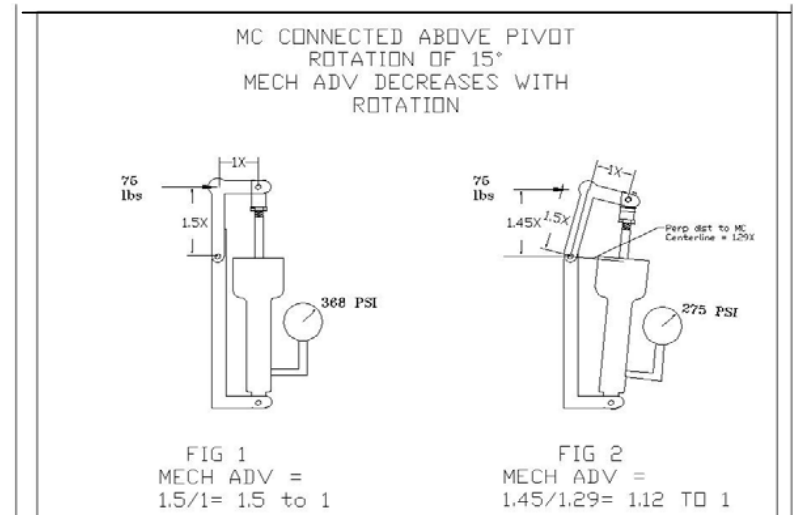

PEDAL GEOMETRY / POOR & MINIMUM

Dia. 2 Figures 1 & 2

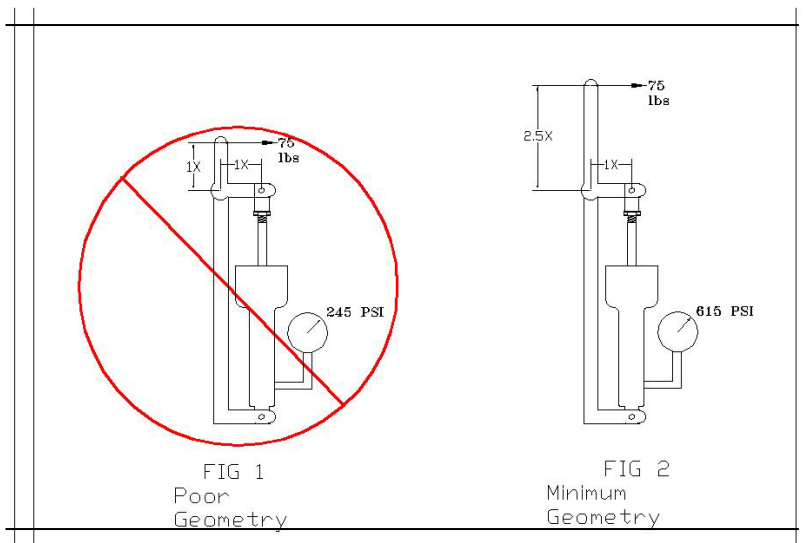

PEDAL GEOMETRY / PIVOT CONNECT

Dia. 4 Figures 1 & 2

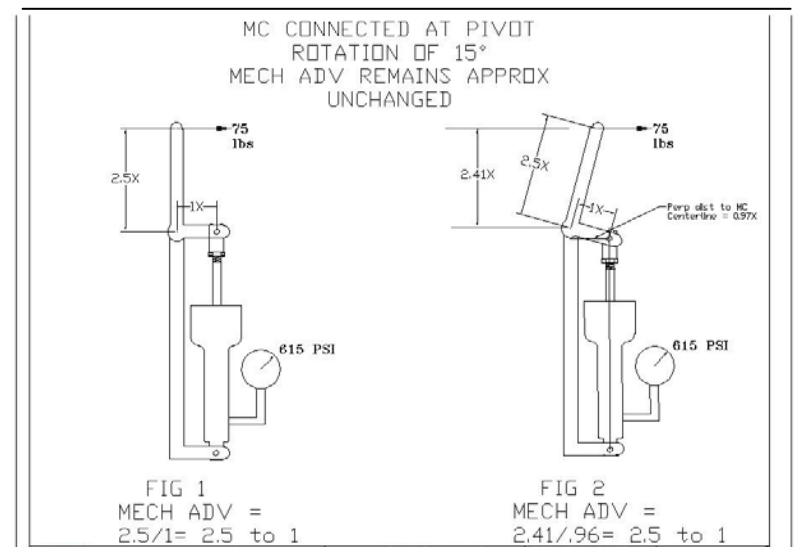

P. LUBRICANTS

PEDAL GEOMETRY / HEEL BRAKES

Dia. 5 Figures 1 & 2

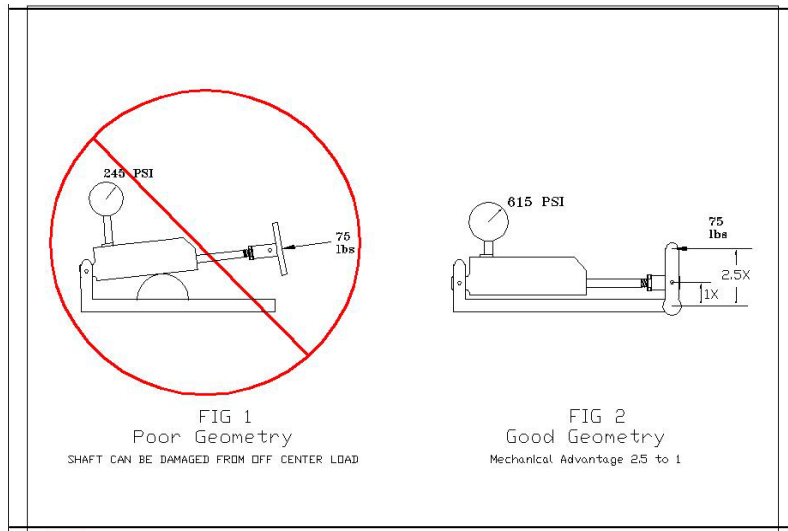

ELASTOMERIC COMPOUND LUBRICANTS

HYDRAULICS: MIL-H-5606 / MIL-H-83282
Or equivalent (Red Oils)

NOTE DOT 5.1 brake fluid is NOT compatible with MATCO mfg brakes, and will damage the Buna-N O-rings used in the system.

PETROLEUM LUBRICANTS

WHEEL BEARINGS: MIL-G-81322
MOBIL 28
MOBIL SHC-100
AEROSHELL 22
Or equivalent lubricants

AMPHIBIOUS: HCF Grease P/N 605
BG Products, Wichita, KS.

WHEEL NUTS / BOLTS: MIL-T-5544 Anti seize
Or equivalent

THREAD SEALANT

TAPERED PIPE THREADS: Loctite 567, or equivalent

Q. TECHNICAL ASSISTANCE

For technical information, product matching, and helpful hints, see our website at:

www.matcomfg.com

E-mail our technical service manager for specific information at:

tech@matcomfg.com

TECHNICAL ASSISTANCE

To speak with someone in person about specific products or to find answers to technical questions, please contact us at our

TECHNICAL HOTLINE

801-335-0582

OR FAX US AT 801-355-0581

Technical Support Disclaimer:

While we at MATCO mfg. strive to ensure that the advice/information provided through our support is correct, MATCO mfg. does not accept any responsibility for errors or omissions. Any advice or information that MATCO mfg. gives you, via any form of communication is not a guarantee that it will correct your problem. It is only offered as assistance to you. MATCO mfg. will not be held responsible for any loss or damage as a result of our advice or information supplied.

NORD-LOCK Washers



NORD-LOCK is a pair of washers with a wedge-locking action meeting DIN 25201 which is a unique method using tension instead of friction. The rise of the cams between the NORD-LOCK washers is greater than the pitch of the bolt. In addition, there are radial teeth on the opposite side. The washers are installed in pairs, cam face to cam face.

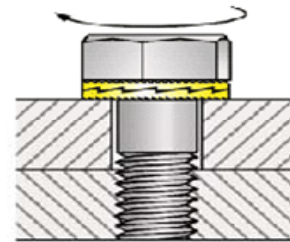

When the bolt and/or nut is tightened the teeth grip and seat the mating surfaces. The NORD-LOCK washer is locked in place, allowing movement only across the face of the cams. Any attempt from the bolt/nut to rotate loose is blocked by the wedge effect of the cams.

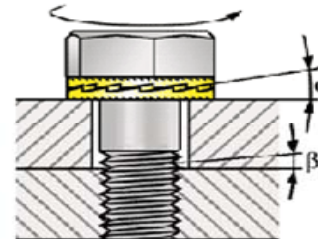

Here you see what happens when a bolt is untightened with a wrench. The pair of washers expand more than the corresponding pitch of the thread allows the bolt/nut to rise.

NORD-LOCK washers positively lock the fastener in a joint which is subjected to any kind of vibration or dynamic loads.

REPLACE the NORD-LOCK washers if the cam surface is worn and corners are rounded or if the pair does not seat cleanly against each other

WHEEL INFORMATION

WHEEL MODEL # _____

(Page 5) BRAKE ASSY _____

(Pages 9 – 11) BRAKE LININGS _____

BRAKE FLUID Mil-H-5606 or equiv. _____

(Page 5) BRAKE DISC _____

(Page 18) MIN DISC THICKNESS _____

NOTES