

For a Full color printout go to:
www.barkeraircraft.com/files/AOA_Display.pdf

This months project

Angle of Attack Indicator.

–Dave Barker EAA Chapter 79

This device is really just a simple weather vane with the axis mounted horizontally to indicate relative wind in the vertical direction as opposed to azimuth for a weather vane on the barn. Why AOA (Angle Of Attack) ? Because it can tell you what the aircraft is really doing compared to the typical variable incidence of the Pitot tube rigidly mounted under the wing. The pivoting vane of the AOA detector always flies directly into the relative wind. The angle it makes with the attack angle of the wing can be measured and provides accurate flight status in high pucker- factor maneuvers such as short take off and landing attitudes. The pick-up makes use of a linear Hall effect sensor. This is a device that outputs a voltage proportional to the strength of a magnetic field. The Vane of the AOA carries a small permanent magnet that rotates with the Vane relative to the Hall sense device located on the Delrin mount sleeve. The output voltage is used to drive a panel mounted 10-segment multicolor bargraph display. The display LED's change position and color from Green to Yellow to Red as the angle of attack increases.

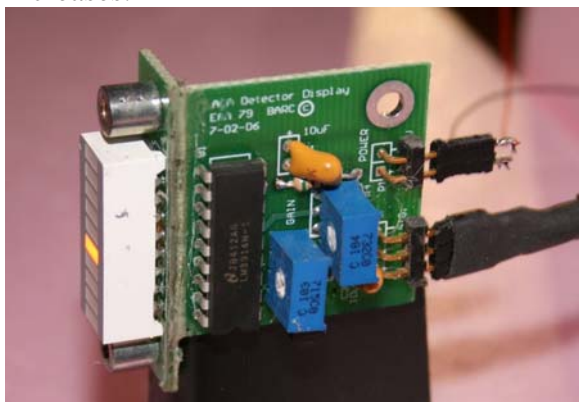

The AOA display board requires minimal panel space, but should be mounted high on the panel to stay within your peripheral field of vision while looking outside.

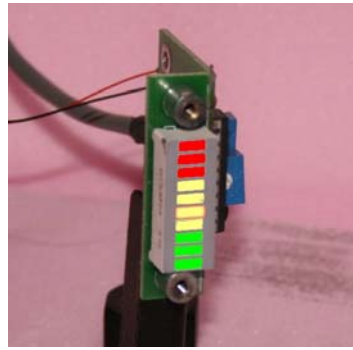

All LEDs ON (Not the normal display)

The hardest part of this project is deciding where to mount the vane assembly. And then routing the connecting cable through the wing to the sensor. The sensor vane needs to be located in the undisturbed airflow away from prop blast and wing Empennage effects.

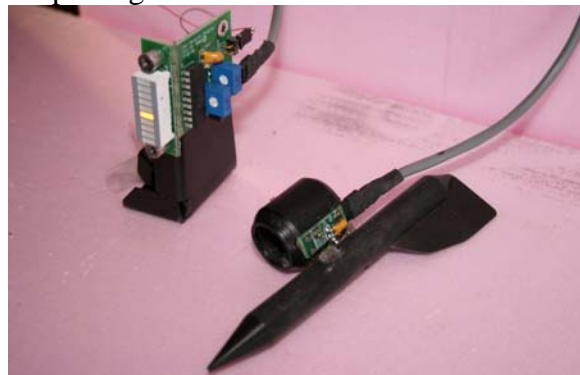

Display and Sensor

In many aircraft mounting parallel to the side of the Pitot tube structure is a good choice. My plane has a typical heated Pitot tube structure and I build a Delrin ring carrier for the Hall sensor and pivot that slides on the Pitot tube and positions the vane parallel and slightly behind the Pitot intake port.

The vane and fin itself can be formed from plastic. I used a piece of Delrin rod equipped with an aluminum fin. For the production version I used a 4-40 SHCS and a 5/16" brass sleeve for a pivot shaft. The vane carries a small 0.375" long rectangular permanent magnetic mounted in the inboard face of the vane about 1/4" ahead of the pivot shaft. The North to South side face of magnet rolls about the pivot parallel to the hall sensor face. By keeping the arc travel

within the physical length of the magnet we can achieve a linear position voltage output from the Hall sensor versus angle of displacement of the moving vane.

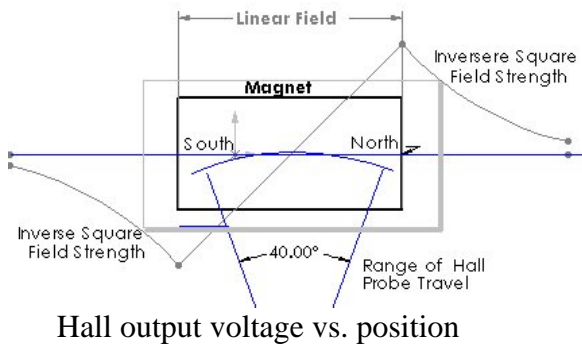

AOA Vane and Mount with Hall Sensor



AOA Pitot Mount (Small hole holds Hall sensor)

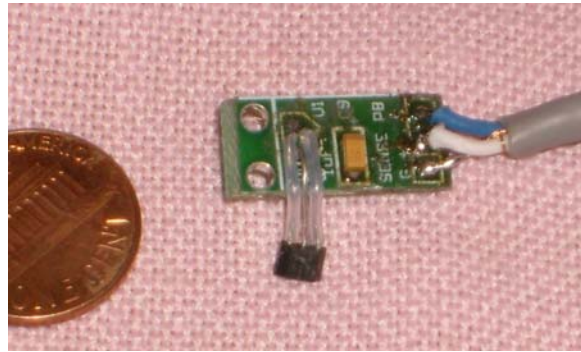

Board with cable and Hall sensor mounted off the side of PC board Note surface mount capacitor (Yellow cube)



To minimize aircraft panel real estate, the top side of the PC board is scored about .030" deep (Red Line below) along the side of the bargraph display. Mount the bare board in a machine vice with the jaw edge along the score mark and bend the board back against the sharp (square) edge. A mill vice is perfect for this operation.

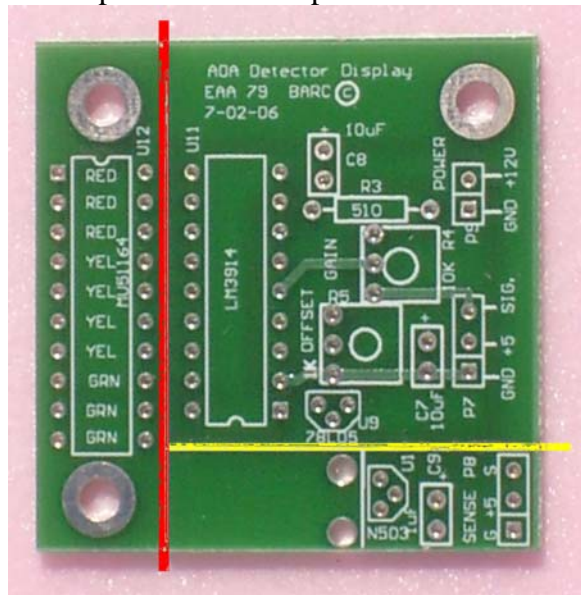

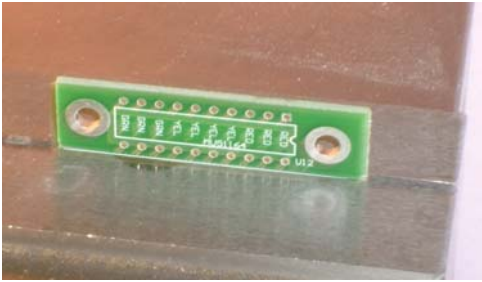

Place in vice at the score line and Break scored line backwards for 90° fold

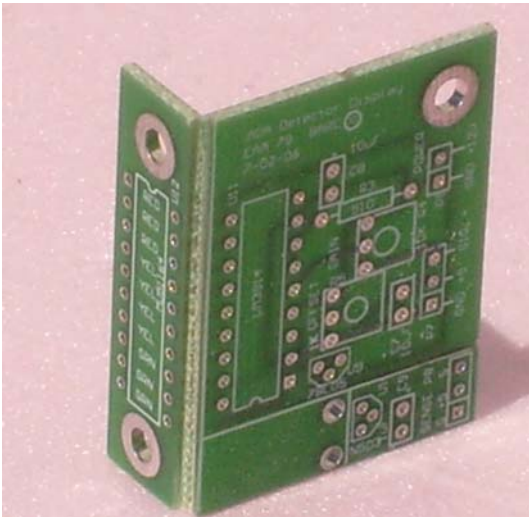

By carefully pushing the display portion backwards over the sharp edge of machine vise, the PC board folds the display portion 90° without breaking the connecting traces on the back surface. Hold it in the 90° position, and fill the gap with glue. If this is done carefully, you will not break any of the copper traces on the backside of the board. However, if you do damage a copper trace, scrape off the green solder mask on the broken trace, tin and bridge solder it with fine copper wire. The sensor portion of the circuit board is cut all the way through and can be broken out completely after the display section fold process. Trim off the unused portion of the Hall sensor board remnant, and install the Hall device magnetic field sensor, plug and capacitor. This PC board is mounted on the Delrin ring sleeve support, which in turn carries the moving vane equipped with its permanent magnet. The magnet moves across the face of the Hall sensor as the aircraft pitches up and down.

Assembly

Populate the board with the components as shown on the board annotation and the photos. Make sure you have the proper part orientation before soldering the parts in place. Note: (Pin 1 of the HDSP –4822 LED display is noted by a dot on its side. The label will be on your left side) This will orient to the upper left corner of the PC board. The LM3914 driver chip orients its pin 1 downward bottom right direction.(notch) Additionally bridge soldering the touching display and driver chip leads that touch at the board fold will provide additional structural strength. Install Hall sensor cantilevered off its PC board ~ 3/8” Hall sensor should be flush with the AOA Mount surface.



AOA Vane Mounted next to Pitot tube (prototype) lock with 4-40 set screw.

The most tedious portion of the job is usually the routing of the connecting cable (two conductor plus shield) from the sensor thru the wing to the aircraft instrument panel.

Calibration

The display board has two blue adjusting trimpots that allow scaling to fit the aircraft performance. Bend the leads 90° and mount these pots on edge. They should be glued as well as soldered to the PC board.

Note the pot marked 842CO R-103 is the 10K ohm value For the Gain set. And the 823CO R-102 is the 1K ohm value for the offset position. This Pot scaling adjustment

will vary if you are flying a trike or a jet. The uppermost trimpot on the display board sets the gain. I.e. How many bars the display moves up and down with each degree of vane rotation. The lower trimpot is an offset adjustment. This moves the span position (bottom green display element turn ON). This bottom, (or second from the bottom) Green LED should be ON when the aircraft is in straight and level flight. The upper RED light should turn on at the stall angle for your particular aircraft and wing design. A peak range of somewhere between 15°– 40° for most aircraft types.

Note: In ground calibration you will be pitching the vane downward to set the gain trimpot. Which is the same as the wing pitching upward while the vane maintains a constant position to the relative wind. Please note the gain and offset pots are somewhat interactive and will require some iteration to zero in on optimum.

Finally, **Please, Please if you are going to check out the limits of performance of your aircraft. Do it with lots of altitude!!!! This device is an indicator. It will not rescue you from sloppy pilotage!**
 Dave Barker -copyright 3/06 revised 9/08

The AOA kit consists of:

Electronic components

- Double sided PC Display boards
- Cut and scored
- SS49 Hall magnetic sensor *
- *(Change of component since SA article)
- LM 78L05 +5V Regulator
- LM 3914 Bargraph Drive
- MV5A164 Multicolor LED Display
- 10K Pot Bourns 842CO- R-103
- 1K Pot Bourns 823CO- R-102
- 510 ohm resistor
- 10uF Capacitor (surface mount)
- 10uF Capacitor
- ~ 1" Teflon Sleeve for hall sensor leads.(Trim to size as required)
- 3 pin plugs (1) PC board mount

- 2-pin plug (1) PC board mount
- Cable termination connectors. (1)
- Power terminal 2 pos Cable mount
- Sensor Cable 3 Position Cable mount
- 17 feet of 2 conductor + shield cable
- Cable Terminals (5)

Mechanical parts

- 1/4" x 4-40 swage type standoff (2)
- Delrin Sensor vane and fin
- Post axle components
 - 4-40 x 3/4" SHCS
 - 0.55" x 5/16" brass sleeve
- Magnet
- 0.374" x 0.1" x 0.1" Smarium Cobalt Vane (White end goes up)
- Delrin Pitot tube Mount Assembly
- 5" x 1/2" Delrin Vane
- Aluminum, fin blank
- To order
- Go to: www.barkeraircraft.com

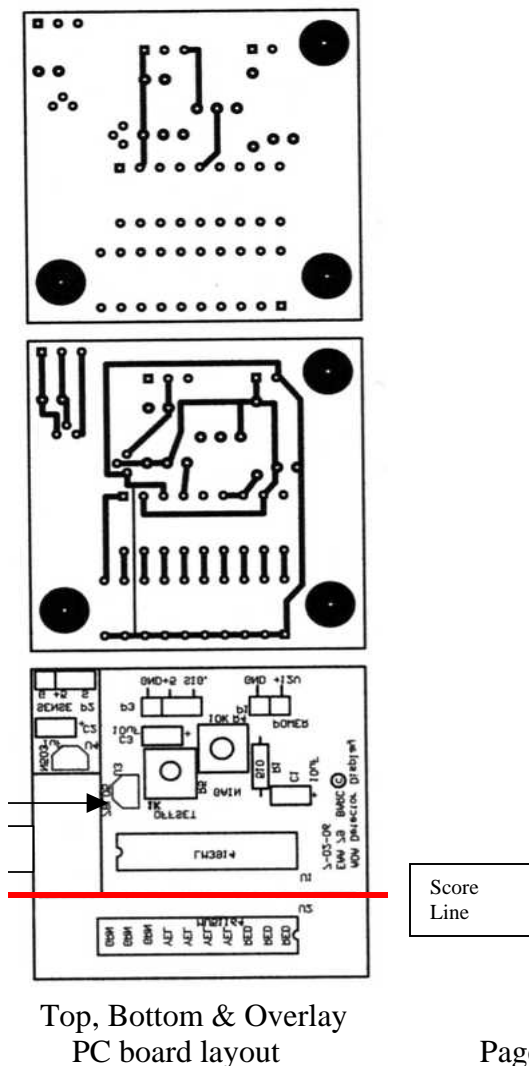

Score
Line

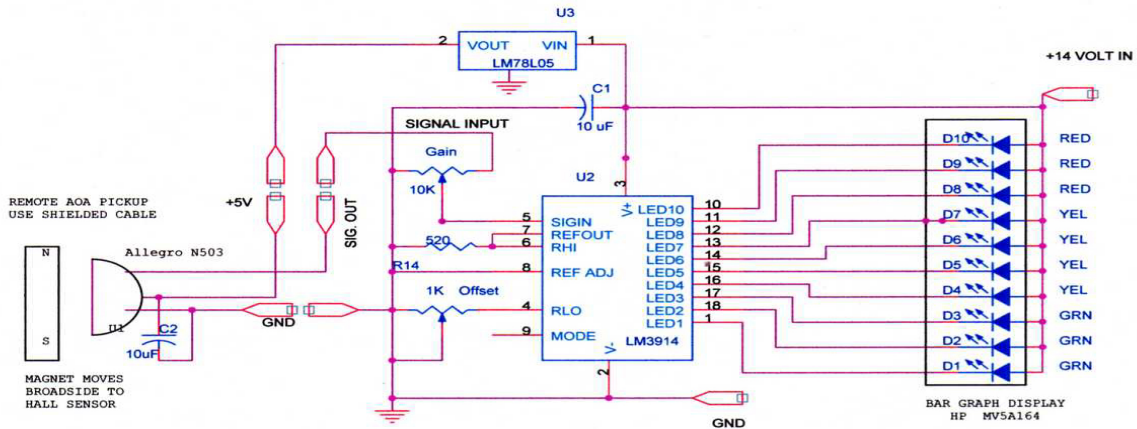

AOA Supplemental construction information

There are a couple of component changes that will affect the kit construction .

- 1) **Connector change.** The two and three contact plugs mounting to the PC boards are slightly different than those show in the Sport Aviation article. The connectors provided in the kit feature a locking tab.. Insert the contacts into the cable receptacle in the Shield (Ground) White (+5V) and Blue (Signal) matching board plug positions.
- 2) Fabricating the cable receptacle connector requires stripping the cable back.
- 3) ~1-1/4" Tinning the wire and shield leads. Solder three of the contacts provided to the white, blue and shield wires. I like to fill the back of the assembled cable with hot glue for strain relief and use shrink tubing to cover the back of the connector/cable interface. Additionally, it may be easier to route the cable thru the aircraft wing and fuselage and panel before mounting the connector the display and sensor board ends of the cable. I initially planned to use the three pin locking connectors and plugs on both ends of the AOA system. However, the locking type connectors are bigger and bulkier than I prefer. Therefore I suggest routing the cable thru the wing to the sensor board and then soldering the cable directly to the PC sense board. Strain relieve the cable /board interface with hot glue and cover with shrink tubing.
- 4) There is a **layout error** on the small Hall sensor board due to a component change from the original design. From a N305 to a SS49 .. The Hall sensor leads are going to require some 3/8" Teflon sleeves and rotating the layout 90° to the pattern on the board silk screen in order to get the leads to the proper pc board pads.

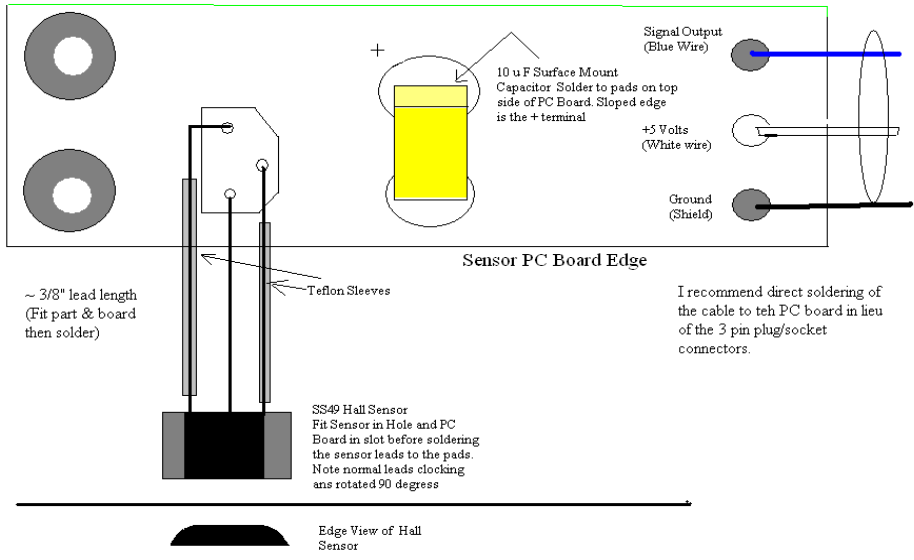

5) **Mount Standoffs** I chucked a 1/4" transfer punch in my drill press and used it as an Arbor press to swage the 4-40 standoff mounts into the face of the display board.

6) **Panel A** reference layout for the display for a 2-1/4" panel mount is attached.

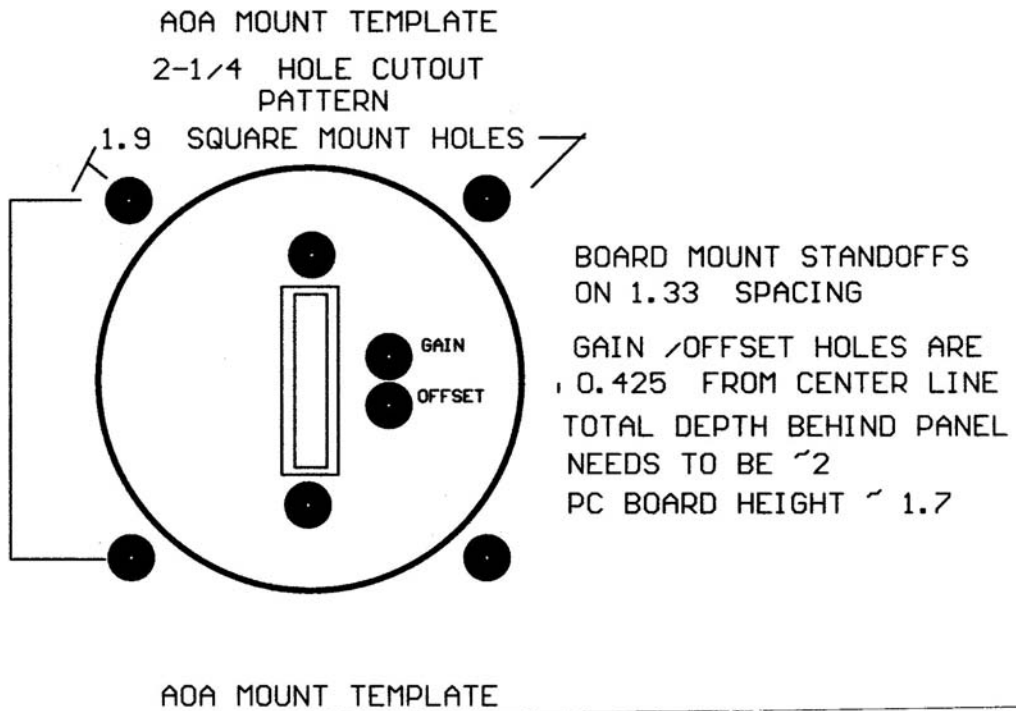

- 7) **Vane Fin** Cut the .025" Aluminum fin stock to shape . Use some gel type crazy glue in the vane slot and press the fin into the slot with a vice.



Fin Template

(Peel protective film off the metal surface)

- 8) **Magnet** .Mount the SmCo magnet in the slot on the inboard side of the Delrin vane. The Delrin does not glue too well . (I have had my best results with hot glue) Orient the magnet with the painted tip up. At the straight and level flight position, the magnet will be tilted backward ~ 45°.
- 9)
- 10) **Pivot**. Use the 5/32" brass sleeve and the 4-40 x 3/4" socket head cap screw as a pivot for the vane.



AOA Vane (without fin), magnet and bearing sleeve (preferred version is to not use 3 pin plug but solder cable directly to PC board.) Some conformal epoxy around the magnet can help hold and streamline the protruding magnet .

- 11) There is a **part change** on the Hall sense board. The 10 uF cap has be changed from a radial lead part to a surface mount part. This part is very tiny. Handle with tweezers and a magnifier and solder to the capacitor location on the board. The Plus + end of the part has the chamfered edge. Straddle and then re-flow solder to the topside pads for the capacitor. Take care not to short the pads. This surface mount part is more difficult to work with but has less wind/vibration issues for this application. A good magnifier and steady hand are very helpful here.



- 12) **Mount the Hall sense** board in the slot on the AOA mount provided. The curve faces of the Hall sensor should be outboard and flush with the surface of the AOA mount structure. Back fill sensor mount hole with glue leaving the sensor face flush with the mount surface. Screw mount or glue as desired to the AOA mount structure. . The board can be conformal coated with a variety of polystyrene dopes or Krylon clear coats for weather protection. Check for rotation clearance. (near zero, but not dragging) as the magnet rotates past the hall sensor face.

- 13) **Finally** Check all wiring and PC boards for cold solder joints. **Correct parts orientation** and polarity. Clean up the solder flux with alcohol . Turn the gain pot to mid range and power up the unit and do some movement tests to assure operation. Start with the lower offset pot full CCW and adjust the gain pot for span (angle versus display movement. The offset pot can be adjusted to get the bottom (second from the bottom) GREEN light at straight and level flight orientation. The Gain pot should be adjust to the top RED for deep stall vane position. As the vane tips downward the bargraph should move up the scale.