

RV7 – EI-EEO Andrew Butler
Main Electrical
Dual Alt, Shared BUS
5/12/08

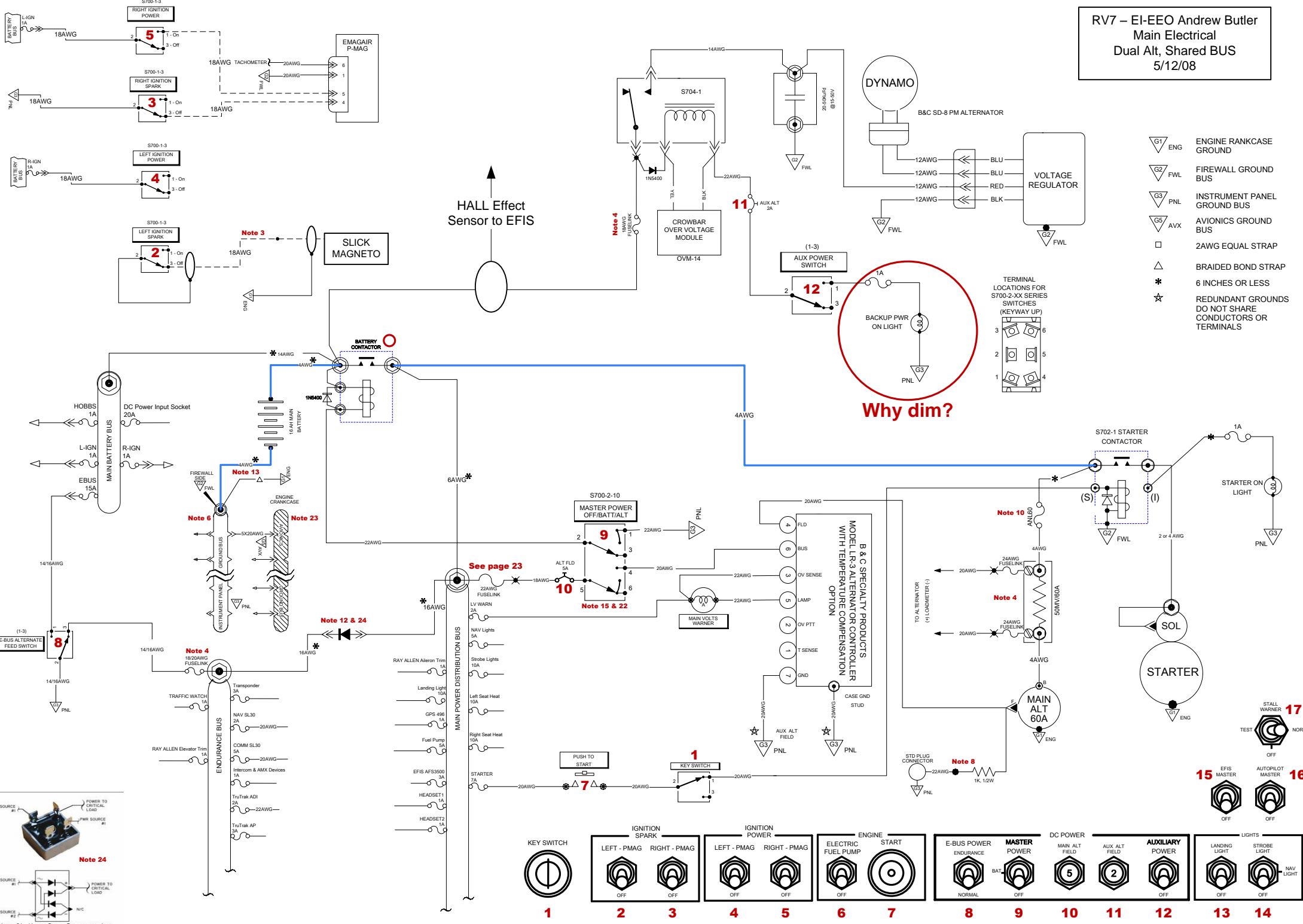

- ▽ G1 ENGINE CRANKCASE GROUND
- ▽ G2 FWL FIREWALL GROUND BUS
- ▽ G3 PNL INSTRUMENT PANEL GROUND BUS
- ▽ G5 AVX AVIONICS GROUND BUS
- 2AWG EQUAL STRAP
- △ BRAIDED BOND STRAP
- * 6 INCHES OR LESS
- ☆ REDUNDANT GROUNDS DO NOT SHARE CONDUCTORS OR TERMINALS

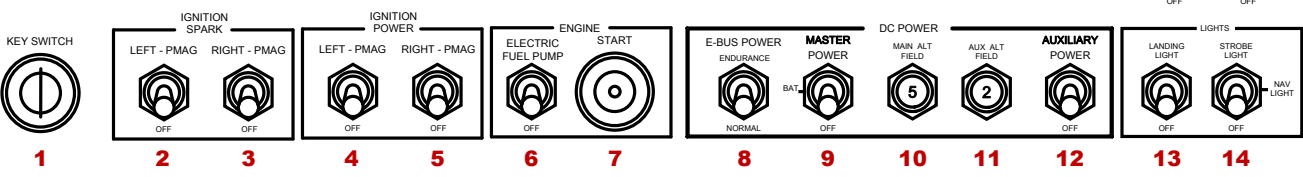
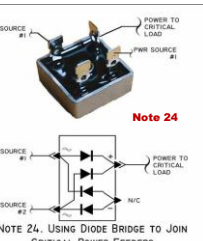
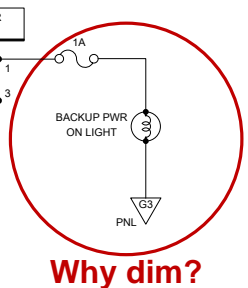
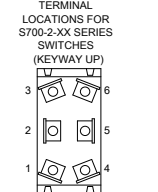

Shield pig tails to mounting frame < 1.25 inches

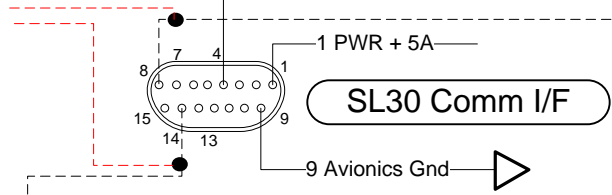

SL30 Comm Configuration:
 RF SQUELCH - 25 to 100; Default 56.
 Microphone Gain - 0 to 255; Normal 128.
 Weather frequencies - Disabled.
 Transmit MIC - MIC1

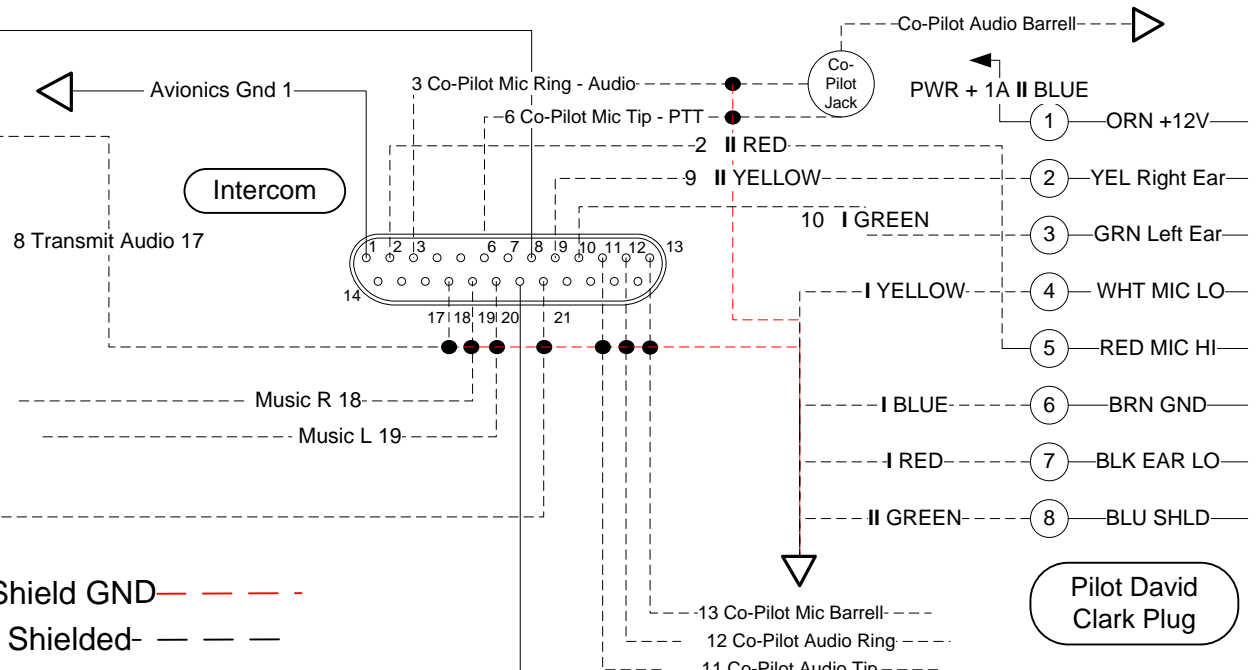

--- Shield GND ---
 - - - - - Shielded - - - - -

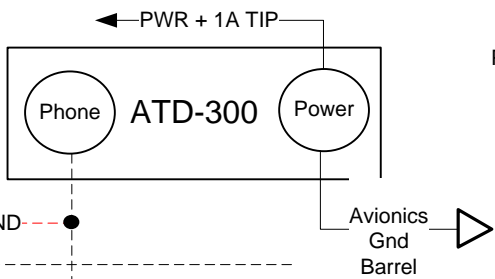
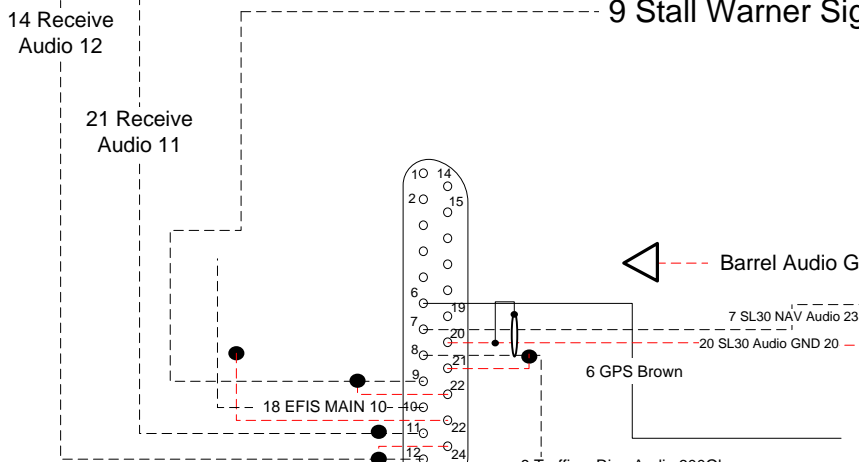

AMX-2A 25 PIN MALE PLUG

**PWR & GND – 20AWG
 All others – 22 AWG**

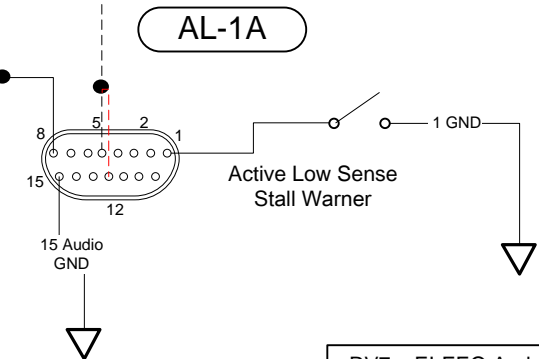

RV7 – EI-EEO Andrew Butler
 Main Audio
 26/11/08

EFIS Main Cable

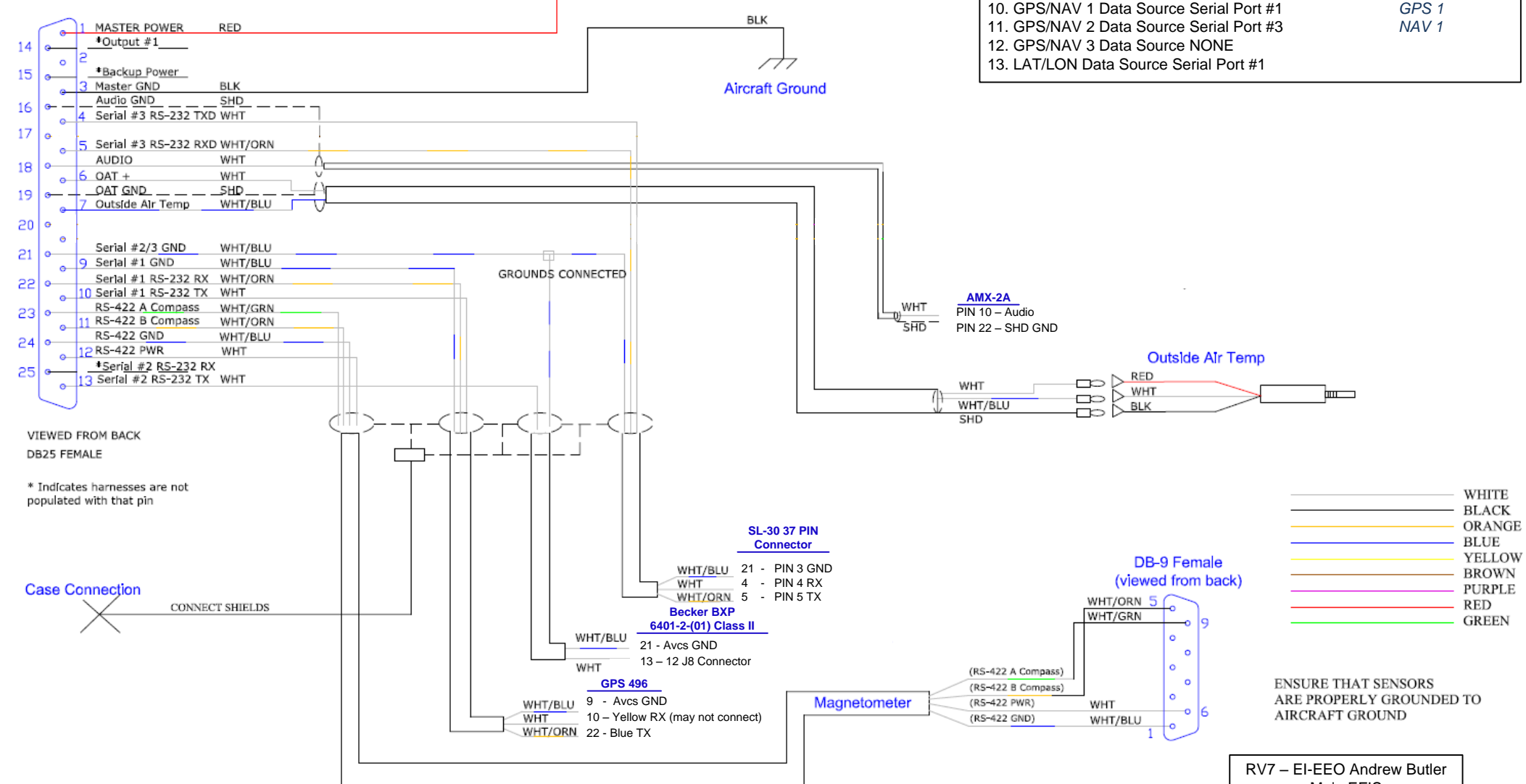

RV7 - EI-EEO Andrew Butler
Main EFIS
26/11/08

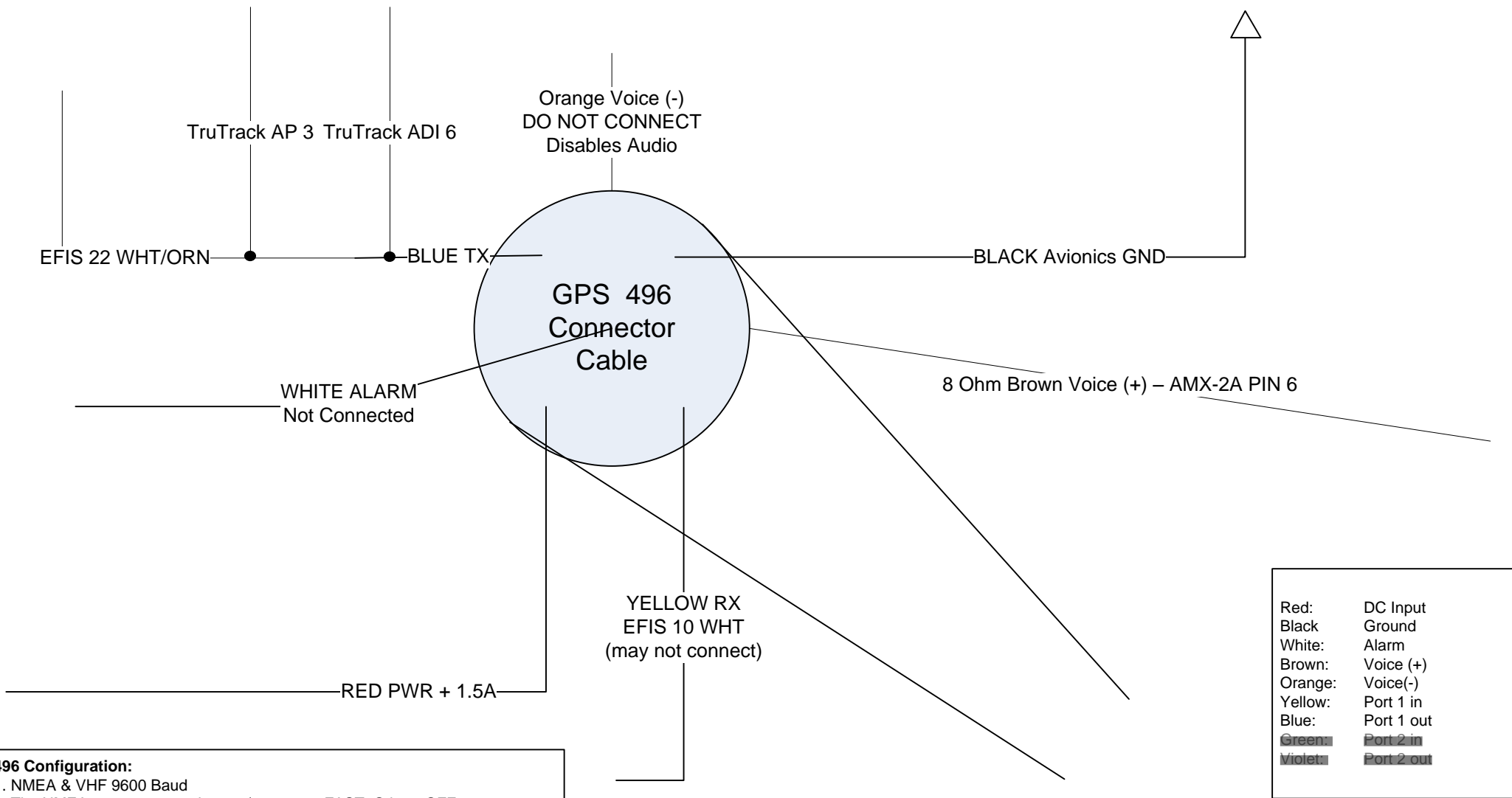

496 Configuration:

1. NMEA & VHF 9600 Baud
2. The NMEA output rate on the 396/496 set to FAST. Others OFF.
 To access the Advanced NMEA Output Setup:
 - a. Press MENU twice to open the Main Menu.
 - b. Use the ROCKER to select Setup from the vertical tab list.
 - c. Select Interface from the row of tabs along the top.
 - d. Highlight the field below Serial Data Format. Press ENTER
 - e. Select NMEAIn/NMEA Out. Press ENTER
 - f. Press MENU to open the options menu. Select Advanced NMEA Setup and press ENTER.

Red:	DC Input
Black	Ground
White:	Alarm
Brown:	Voice (+)
Orange:	Voice(-)
Yellow:	Port 1 in
Blue:	Port 1 out
Green:	Port 2 in
Violet:	Port 2 out

RV7 – EI-EEO Andrew Butler
 GPS Wiring
 26/11/08

TruTrak Autopilot

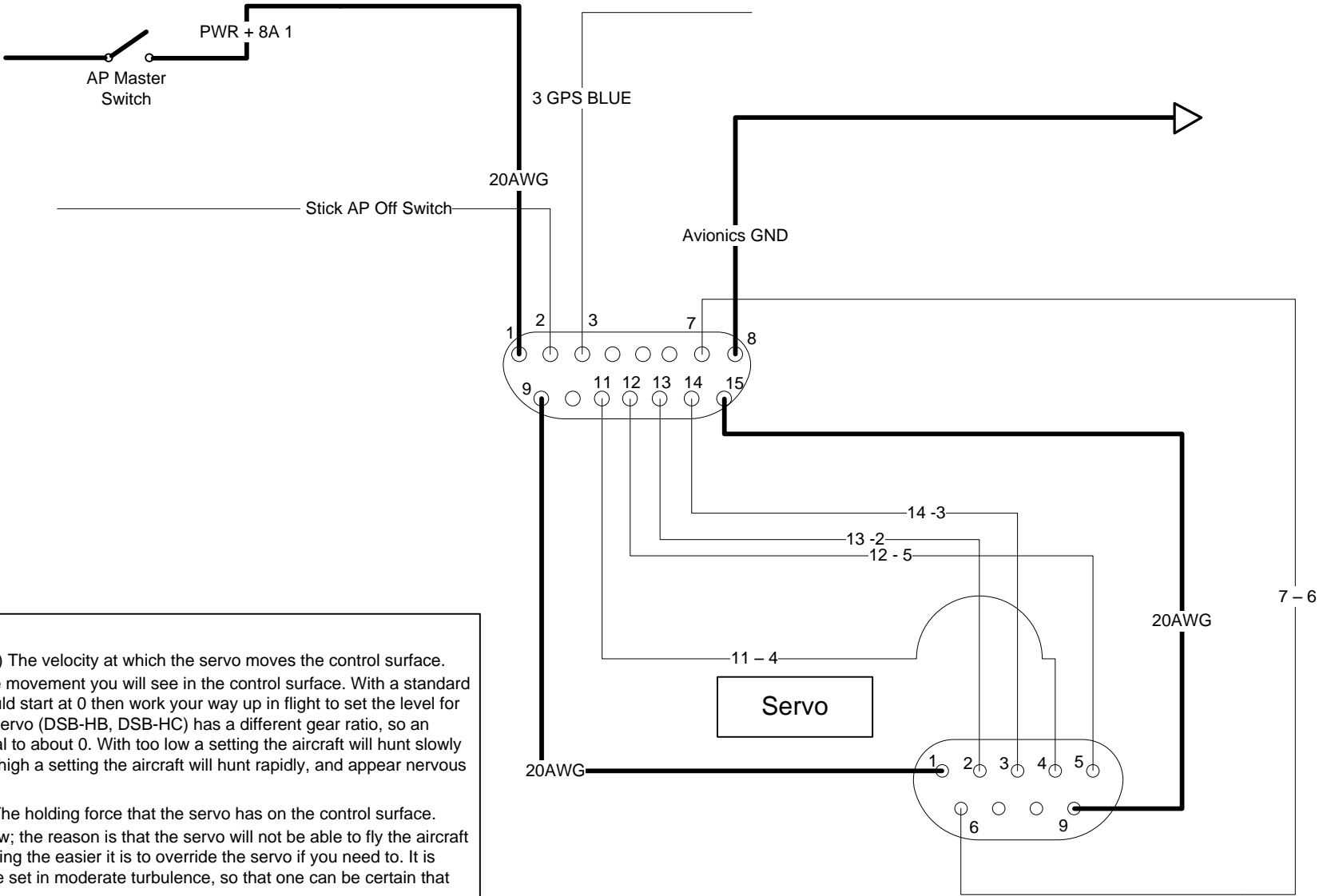

TruTrak Configuration:

- **ACTIVITY** (Setting range 0 – 24) The velocity at which the servo moves the control surface. The higher the number the more movement you will see in the control surface. With a standard servo (DSB-X, DSP-X) you should start at 0 then work your way up in flight to set the level for your aircraft. The High Torque Servo (DSB-HB, DSB-HC) has a different gear ratio, so an Activity setting of 12 will be equal to about 0. With too low a setting the aircraft will hunt slowly and appear to be lazy. With too high a setting the aircraft will hunt rapidly, and appear nervous and jittery.
- **TORQUE** (Setting range 0-12) The holding force that the servo has on the control surface. This setting should not be too low; the reason is that the servo will not be able to fly the aircraft in turbulence. The lower the setting the easier it is to override the servo if you need to. It is recommended that the torque be set in moderate turbulence, so that one can be certain that the level is not set too low.
- **BAUD RATE** 9600.

Engine Sensor
Main Cable

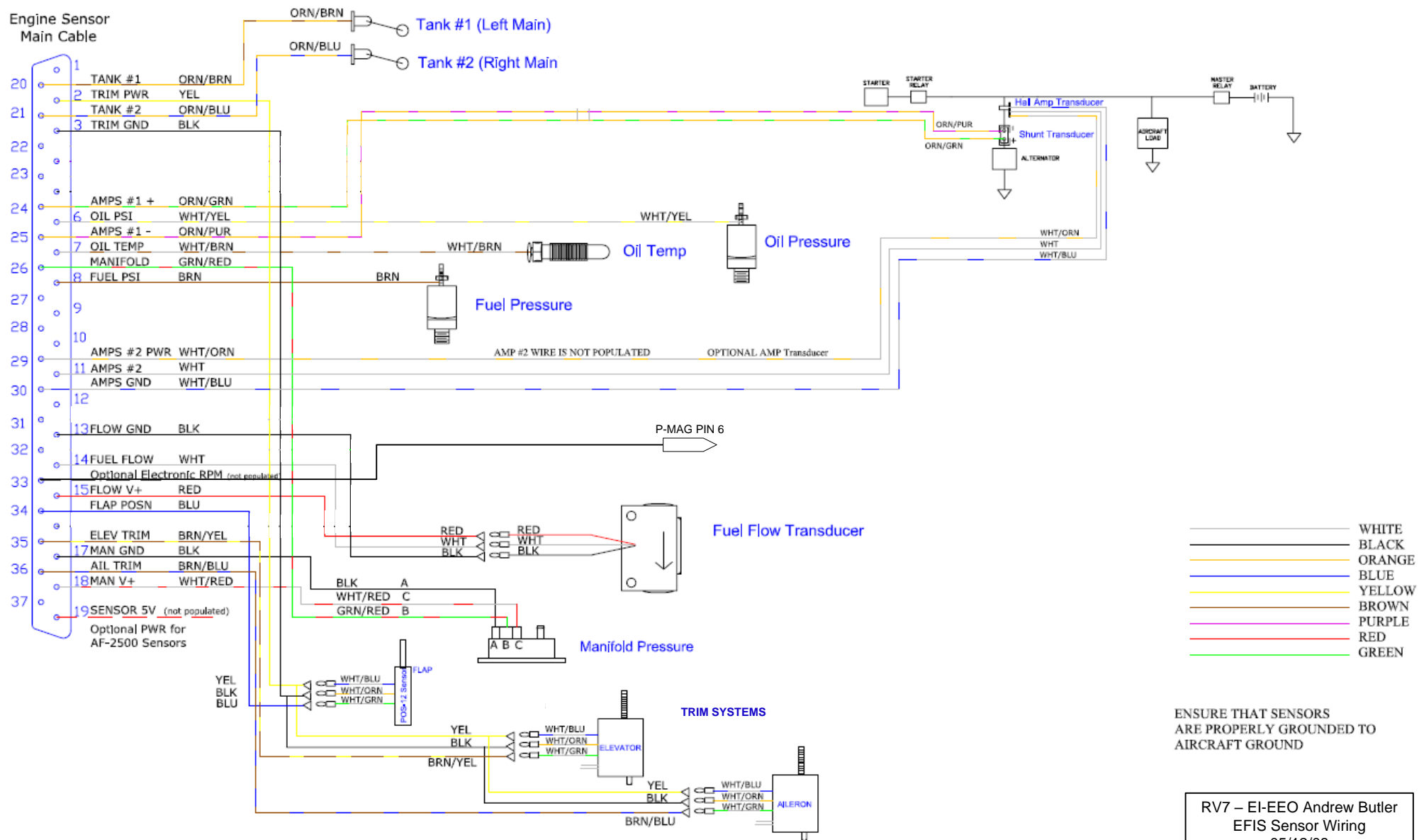

RV7 – EI-EEO Andrew Butler
EFIS Sensor Wiring
05/12/08

SL30 Setting: Indicator Head Type: None.
Enables OBS to be set from SL30 or from the EFIS

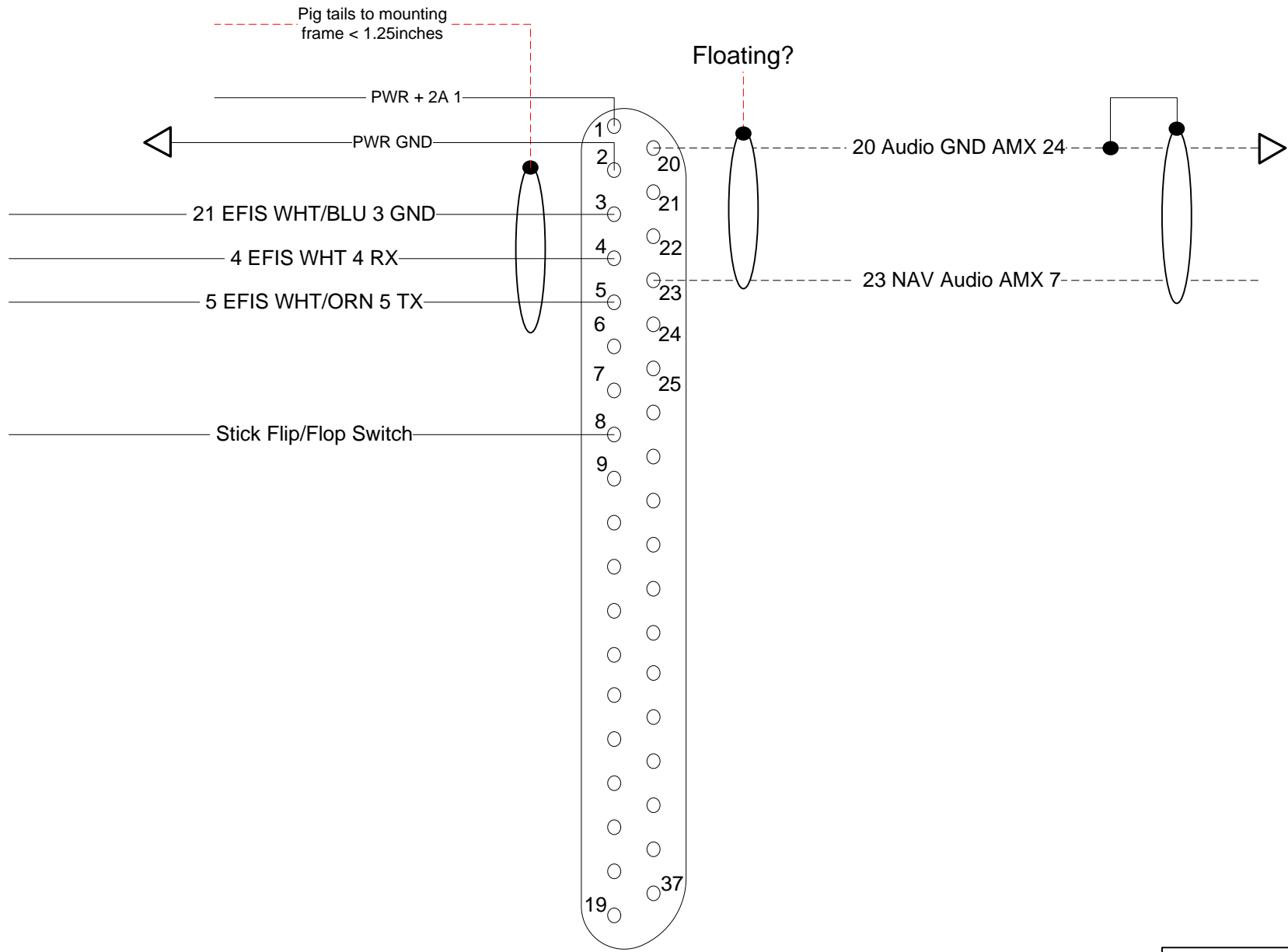

TruTrak ADI

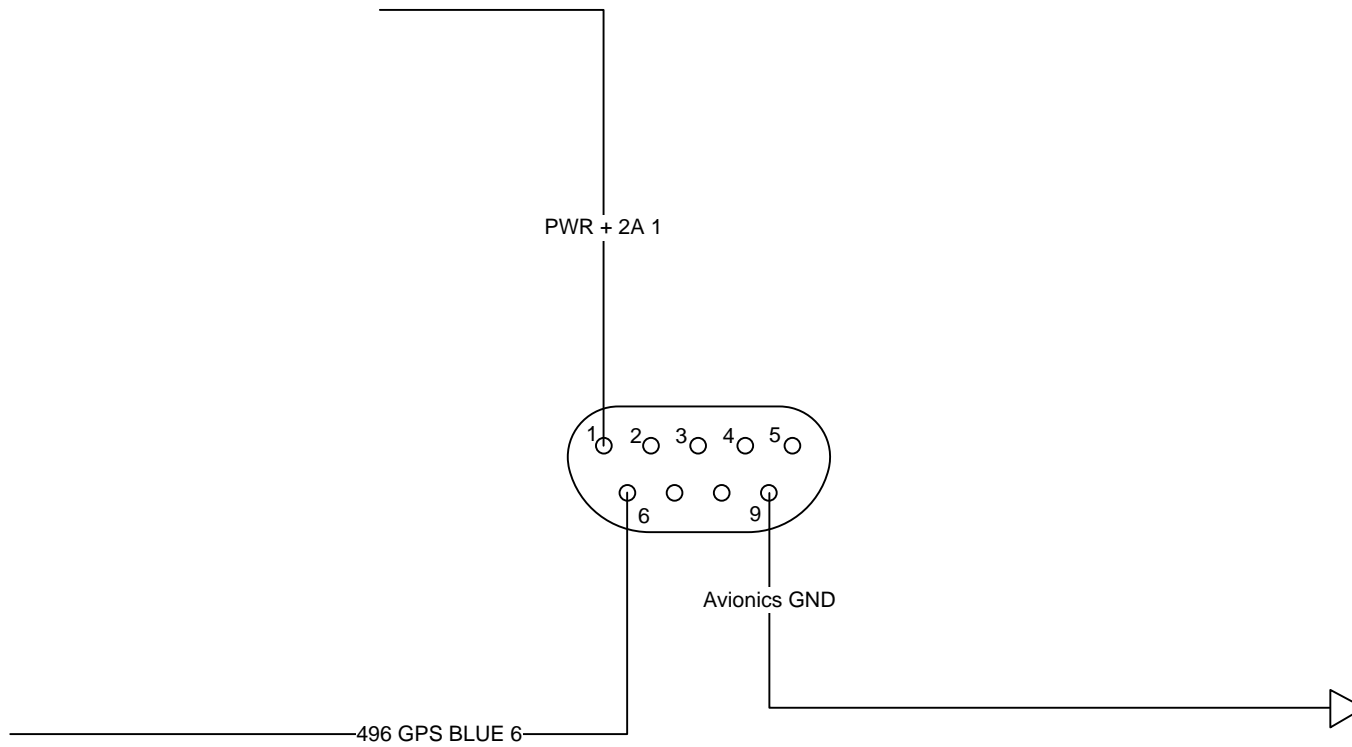

Transponder Configuration:

- Select with button (C) Select with rotary encoder (B) Store button (F)
- ALTM SELECT - MAGELLAN
- DIMMING INPUT - Default None & Brightness 50%
- SQUITTER Short ACQ SQU - Default On
- REPLY RATE LIMIT - 500-1200 replies/sec.
- SPECIALS DATA LINK - Disabled if no ADLP device connected

* Transponders equipped for extended squitter operation should have a means to disable acquisition squitters to facilitate the suppression of acquisition squitters when all TCAS units have been converted to receive extended squitter

**Becker BXP
6401-2-(01) Class II**

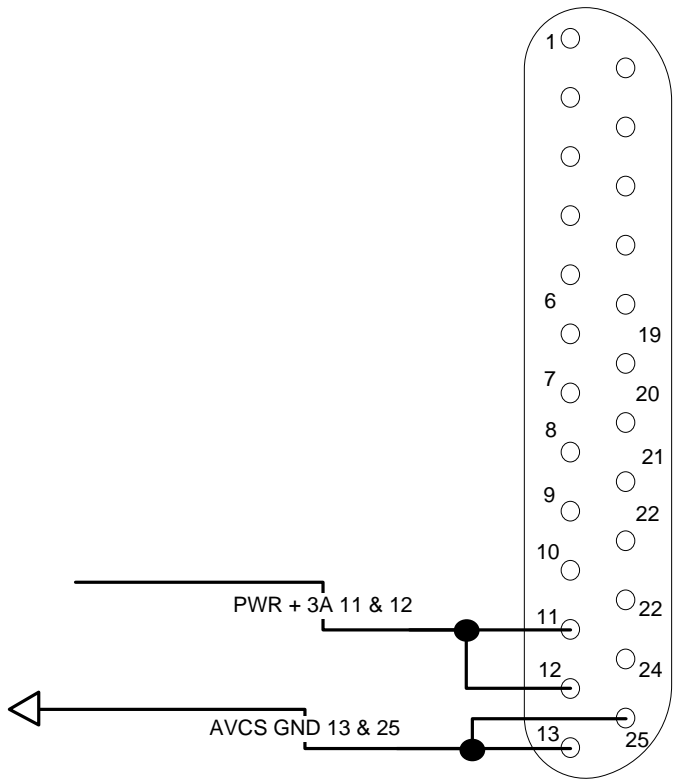

**P9 25 PIN
MALE**

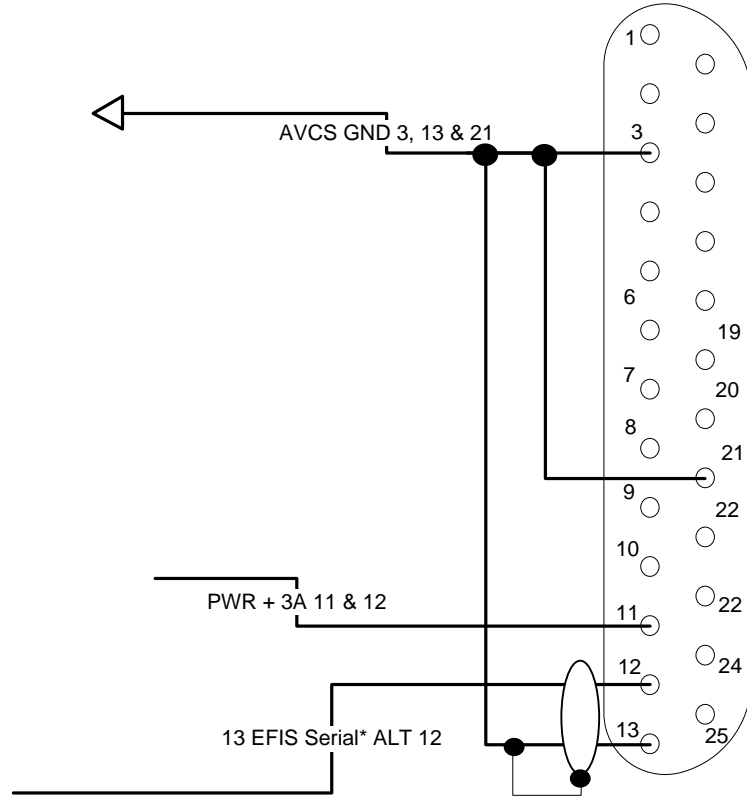

**J8 25 PIN
FEMALE**

* Magellan Format

Ray Allen Trim Systems

RV7 – EI-EEO Andrew Butler
Trim Wiring
05/12/08

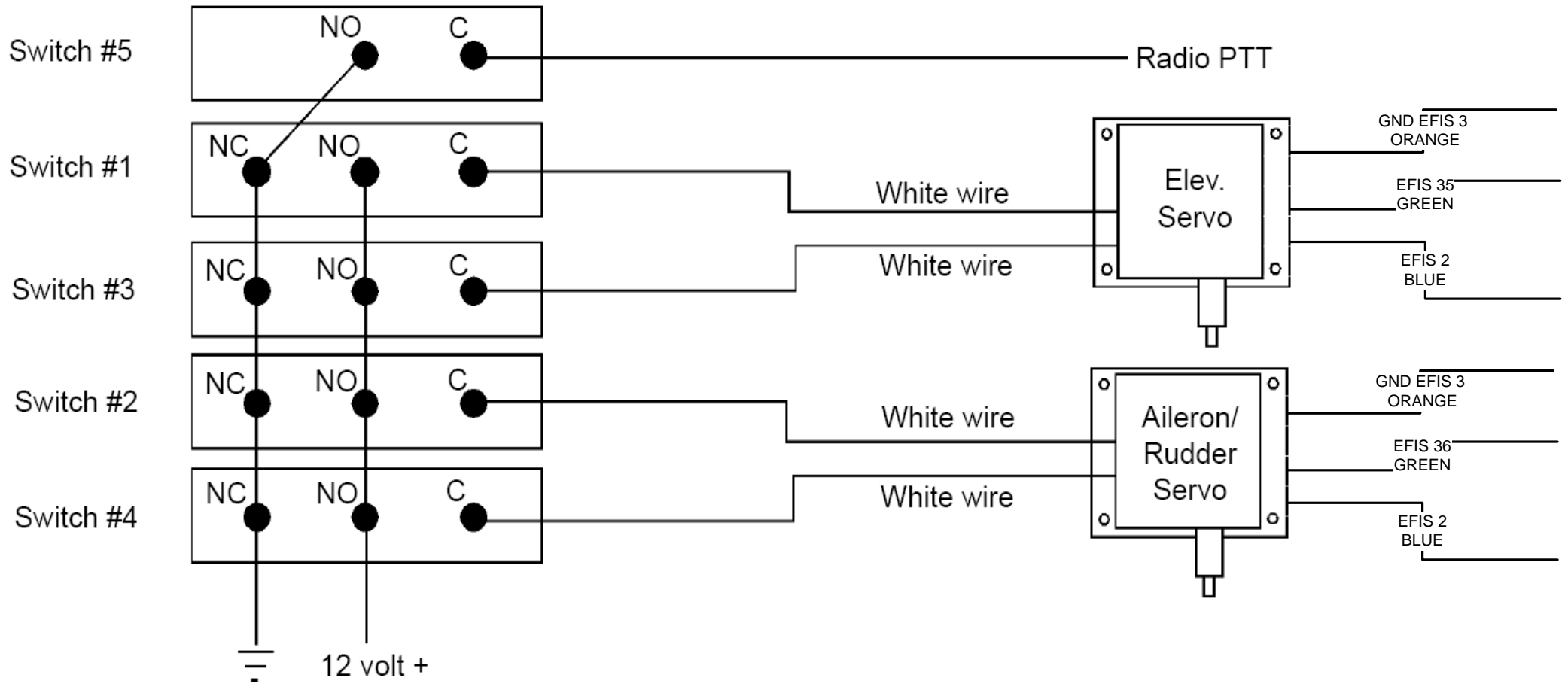

Wiring must accommodate separate master switches for each trim servo. Location of the switches in the power circuits to be determined.

Figure 1A

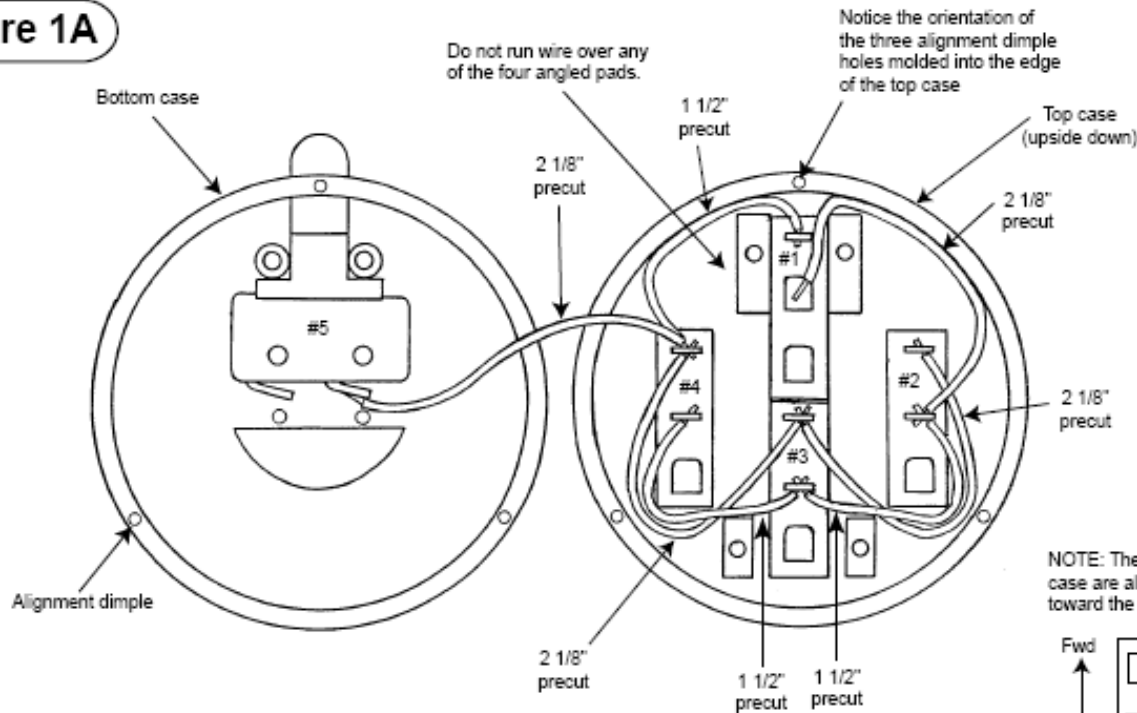

Wiring must accommodate separate master switches for each trim servo. Location of the switches in the power circuits to be determined.

NOTE: The four switches in the top case are all oriented with the NC tab toward the front of the case, as shown.

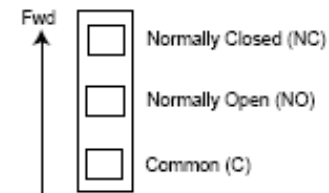
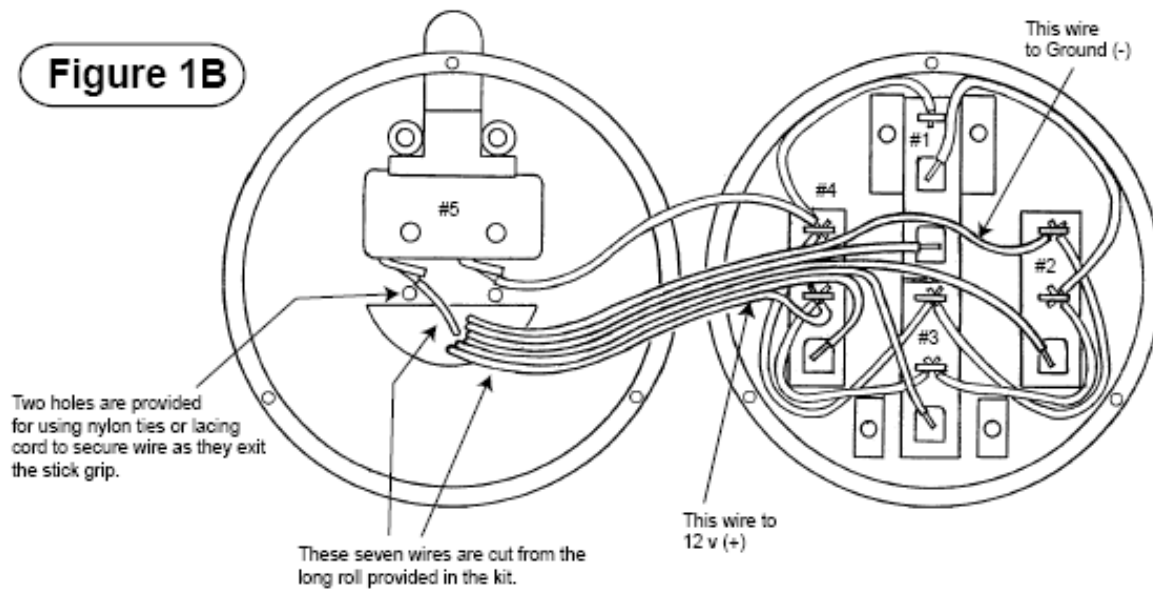

Figure 1B



Wiring of momentary switches not shown. One will be connected to SL30 NAV 37 PIN Connector, PIN 8. Other to be determined.

Note 1. The minimum recommended wire size for all wiring is 22AWG except as noted. Try to keep wires marked with an asterisk (*) limited to 6" or less in length.

Note 3. Use shielded 20 or 22AWG wire to control the mags. Attach the shield to engine ground at the magneto end. Attach the shield to one and only one switch terminal at the cockpit end as shown. In the switch OFF position, the shields are used as a ground return for the magnetos. In the MAG ON position, the shields are protection from electrostatic coupling of magneto noise. The shields should not be attached to any form of ground at the panel, just the magneto switch.

Note 4. Automobiles have been using fusible links for many years. From the outside, they appear rather "special" . . . many have a tag molded onto what looks like a piece of wire with a terminal on one end . . . the tag says, "FUSIBLE LINK." Hmmm . . . well guess what, what looks like a piece of wire is indeed a piece of wire . . . and rather ordinary at that. After lots of e-mail, phone calls and literature searching I've deduced the rationale behind design and incorporation of fusible links.

All fusible protection of a wire functions the same way. A thermally weaker segment is placed in series with the wire segment to be protected. Sometimes the link is a piece of special wire inside a glass tube or block of plastic and we call it a "fuse". The purpose of the weak link is to provide an orderly failure of a faulted circuit's ability to carry current. Suppose the weak link was simply a piece of ordinary wire? It turns out that the link used on cars is 4AWG wire steps smaller than the wire being protected. 10AWG wires are protected by 14AWG links, 14AWG wires are protected by 18AWG links, etc. Obviously, should a hard fault occur, you WILL get some smoke and the smaller wire will melt and separate. Successful incorporation of fusible links takes some consideration . . . they're not for every situation which might otherwise require some form of in-line fuse.

First, 24AWG is the smallest practical wire that can be worked with terminals and tools used. A 24AWG wire will carry a 3A continuous load with a reasonable temperature rise. The downstream segment from a 24AWG fusible link has to be 20AWG. Hmmm . . . a tad heavy for a 3A circuit but not outrageous. Take a look at the alternator loadmeter shunts on Figure Z-14. Short pieces (4-6 inches) of 24AWG wire are butt-spliced onto 20AWG extensions to take shunt signals into their respective loadmeters.

Now, how likely is it that these "fusible links" will ever be called upon to do their job? . . . VERY small. What's the damage if it does happen? Not much: a short piece of 24AWG wire burns up. If we slip a piece of fiberglass sleeving over the wire, you wouldn't even toast an adjacent wire in a bundle. Why would we want to do this? Lower parts count for one, increased reliability for another. All components of this protection scheme are ordinary pieces of wire connected together with solderless splices and terminals having reliability approaching that of the wire itself . . . *much easier to install and more reliable than any form of holder for discrete fuses.*

Hmmm . . . how about the Aux Alternator B-lead feed in Figure Z-14? Here's a special challenge that is nicely met with a fusible link. Here the B&C SD-20 alternator is capable of 20 amps of continuous output. In-line fuse holders at this current level are marginal at best; fuseholder components corrode, accelerated by moisture and temperature cycles. The fusible link is a very reliable alternative for circuit protection in this location.

I show fusible links on other single line feedpaths as well. Our website catalog will soon offer small quantities of 24AWG tefzel wire (not commonly offered in other folks catalogs) and small quantities of silicone rubber impregnated fiberglass sleeving to place over fusible link installations. This sleeving is not necessary but it does offer some protection to adjacent wires and equipment from effects of heat and smoke.

Note 6. The ground busses shown are fabricated from brass sheet, strips of .25-inch Fast-On tabs and a brass bolt. These are available from B&C Specialty Products.

Note 8. When an alternator quits alternating, good data is useful in making an accurate diagnosis of the problem. If you don't know what the alternator field voltage is doing when the system is failed or misbehaving, you're not ready to put a wrench to the airplane. There are few mechanics out there that even know about what you're going to learn here . . . and even fewer that will stand behind a running propeller to gather the needed information. So consider this: Referring to Figure Z-23, you can see where a 1K, 1/2 watt resistor can be spliced into the alternator field lead at any point along the route between the regulator and the alternator's field terminal. Splice a 22AWG wire to the other end of the resistor and then cover the whole business with heatshrink before you tie it back into the wire bundle. The resistor serves as a current limiting device to isolate the test wire from the field wire and eliminate the need for a fuse to protect the test wire. The resistor also prevents a shorted test wire from upsetting normal alternator operations. Now, extend the wire into the cockpit where you'll attach it to a Radio Shack 274-1576 receptacle. The receptacle is small and would not take up much room on a panel but if you want it out of sight, at least make it easy to reach from the pilot's seat--perhaps on a bracket behind the panel. Ground the receptacle's shell to the instrument panel ground bus with another piece of 22AWG wire.

You'll need to make up a short cable assembly consisting of a Radio Shack 274-1573 plug (mates with receptacle above) and banana plugs on the other end to connect with a handheld multimeter . . . preferably an analog meter but if all you have is a digital, it will do. We'll cover this in more detail in a future update to the alternator chapter but here's how this feature becomes really useful:

- If the alternator field voltage is zero when the output is zero, then the regulator or associated wiring has failed.
- If the alternator field voltage shows some fairly healthy reading on the order of 10 volts or more and alternator output is zero, the alternator has failed.
- If the alternator has become unstable . . . loadmeter is jumpy, panel lights flicker . . . watch the field voltage and compare it with loadmeter readings. If the field voltage and loadmeter readings swing up and down together, then the regulator has become unstable. Check for increased resistance in regulator field supply wiring and components. Breakers, switches, overvoltage relays, and connectors are all contributors to regulator instability when their resistance ages upward a few milliohms in resistance.
- If the loadmeter swings UP while the field voltage is swinging DOWN, then the alternator has some unstable connections inside . . . perhaps worn brushes?
- If field voltage is high, does not drop significantly when engine RPM increases but bus voltage seems normal under light load and sags under heavy loads, then the alternator may have one or more diodes open/shorted.
- While operating with full system loads, carefully observe the engine RPM where alternator field voltage peaks: i.e. begin at idle RPM with all loads ON--if your bus voltage is lower than the regulator setpoint, then the alternator is

turning too slow to support present loads. Now, adjust engine RPM carefully to get the highest possible reading on field voltage. At this time, the bus voltage should be at the regulator setpoint. The engine RPM is your *minimum speed for regulation* at full load. If your system is working properly and pulley ratios are appropriate, engine RPMs should be equal to or LESS than required to sustain flight. (g) Should your alternator suddenly become "noisy" in that alternator whine becomes markedly worse, you may have suffered a blown diode in the alternator. Before taking the alternator off the airplane, Attach a multimeter to the alternator case and the b-lead (output terminal). Set the multimeter to read AC voltage. Run the engine up and turn everything electrical ON. If the AC voltage exceeds 500 millivolts, there's a good chance that a diode is bad. If it's less than 200 millivolts, then it's more likely that the noise is getting into your audio system via a ground loop (noise is present even when radio volume is all the way down) or failed noise filter (noise goes up and down with radio volume control). The above paragraphs describe about 100 times more than most mechanics know about alternator troubleshooting but none of it is possible unless you can measure field voltage (sometimes in flight), observe a combination of effects and deduce their meaning. The parts cost a few dollars and the feature adds significantly to the efficient and safe maintenance of your airplane.

Note 10. There are good reasons for not bringing high current feeders or loads into the cockpit. The high performance airplanes use a special, heavy duty fuse-like device called a *current limiter*. We've upgraded our recommendations for alternator b-lead protection from the JJS/JJN series fast fuses to ANL series current limiters used throughout the industry for similar applications. Alternator noises in the system are reduced by *not mounting the alternator breaker on the panel* in the traditional fashion. The likelihood of recovering use of the alternator should this breaker trip is very close to zero. Consider installing the breaker (or fuse) as close as possible to the starter contactor.

Note 12. A silicon diode having a forward current rating of 20 amps or more can be used to eliminate a bus tie switch and provide automatic isolation of the power distribution bus from the endurance bus during failed alternator operations. If your endurance bus is configured per our recommendations for 3-4 amps MAXIMUM continuous load, the rectifier diode array requires no heat sinking. A Radio Shack cat #276-1185 is suitable. Its metal case may be bolted directly to the structure. If you absolutely must have higher endurance bus loading, consider ordering your endurance bus normal feed diode from us. We'll put it on a suitable heatsink for you -OR- a Digikey HS117-ND heat sink cut in half is about right for diode cooling.

Note 13. The battery minus (-) wire should go directly to the nearest ground system tie point. I recommend some combination of the Fast-On tabs ground busses (B&C or equal) screwed to firewall. Where ever possible, the battery (-) lead should bolt to the 5/16" brass stud that comes with the ground bus kit. Then a 2AWG equivalent bonding jumper to ground the engine's crankcase to the Fast-On bus.

Note 15. In order to take advantage of the unique switching features of special switches shown in these diagrams, a means of calling out mounting orientation is needed. Switches supplied by the AeroElectric Connection (and other quality devices) are fitted with a keyway groove along one side of the threaded mounting bushing. The numbers given on this drawing for wiring the switch assume that you mount these switches with their keyways up. Your switch should also come with a keyed and tabbed

washer used to prevent rotation of the switch in the mounting hole should the nuts loosen. We recommend its use.

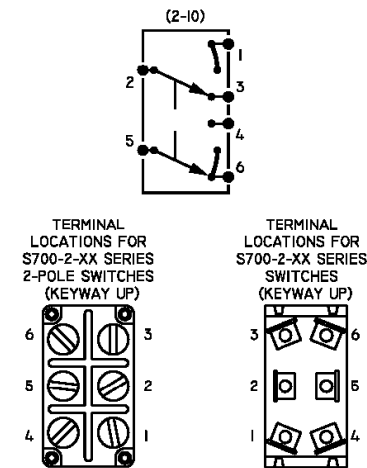

Note 22. Most alternators do not run well without also having a battery on line. The infamous "split rocker" switch was developed for light aircraft in the mid 1960s when generators were being phased out in favor of the much more efficient alternator. The two-pole, split-rocker controlled the battery master contactor with one pole and alternator field excitation with the other pole. The switch halves were mechanically interlocked such that the battery could not be turned off without taking the alternator off as well. The Zfigures always show a two-pole switch as a DC PWR MASTER, one pole for the battery contactor, a second for the alternator field supply. **The progressive transfer, 2-10 style switch** can emulate the popular split-rocker switch by offering an OFF-BATBAT+ALT function. This configuration allows battery-only ops for ground maintenance and covers in-flight situations where the pilot needs to shut down a mis-behaving alternator.

Note 23. Revision 11 introduces the avionics ground bus described in Chapter 18 and illustrated on these figures for the first time

Note 24. When you have critical loads that you would like to accommodate with dual power sources, the 4-diode bridge rectifier offers an easy to acquire, easy to mount, easy to wire solution. The figure for this note illustrates which terminals are used. Figure Z-19 shows one example of how the device is used.

If your critical system draws more than 4 but less than 8 amps, the diode bridge should be mounted on a metallic surface for heat sinking. If the loads are heavier, say 8 amps up to the 25 or 30 amp rating of the device, perhaps a finned heat sink is called for. Consult the membership of the AeroElectric List for guidance in these special cases. In any case, the diode bridge should be located as close as practical to point were the system being supported accepts input power.

	DESCRIPTION	MODEL	FUSE	NORMAL OPS INTERMITTANT MAX. LOAD	NORMAL OPS CONTINUOUS MAX. LOAD	MAIN ALT OUT INTERMITTANT MAX LOAD	MAIN ALT OUT CONTINUOUS MAX. LOAD	SWITCH TYPE	SWITCH	SWITCH LABEL
MAIN BUS	Starter Contactor	B&C	-	1.00	-	-	-	PUSH BUTTON	S895-1	START
	Battery Contactor – MAIN MASTER	B&C	-	1.00	1.00	-	-	ON-ON- BOTH	(2-10)	MASTER POWER
	Nav Lights	Whelen System 6		4.00	4.00	-	-	ON-ON- BOTH	(2-10)	NAV LIGHTS
	Strobe Lights	Whelen System 6		7.00	7.00	-	-			STROBE LIGHTS
	Land Light			8.00	8.00	-	-	OFF-ON	(1-3)	LANDING LIGHT
	Main Voltage Regulator	B&C	2	2.00	2.00	-	-	-	-	-
	ALT Field	L-60	5 (Breaker)	1.00	1.00	-	-	-	-	-
	Heated Passenger Seat	Classic Aero	10	5.00	5.00			OFF-ON	(1-3)	Right Seat
	Heated Pilot Seat		10	5.00	5.00			OFF-ON	(1-3)	Left Seat
	GPS	GARMIN 496	1	0.10	0.10			-	-	-
	Aileron Trim Servo	Ray Allen	1	0.15	0.15			-	-	-
	DC POWER Socket	Steinair SA-9901	20	-	-			-	-	-
Electric Fuel Pump	Airflow Performance	10	5.00	-			OFF-ON	(1-3)	ELECTIC FUEL PUMP	
ENDURANCE BUS	NAV/COM	GARMIN SL30	2	0.50	0.50	0.50	0.50	-	-	-
			5	3.20	-	3.20	-			
	Mode S Transponder	Becker	3	0.50	0.50	0.50	0.50			
	Traffic Watch	Monroy ATD-300	1	0.18	0.18	0.18	0.18	OFF-ON	(1-3)	Traffic Watch Master
	Elevator Trim Servo	Ray Allen	1	0.15	-	0.15	-	-	-	-
	Flaps Motor	Van's	3	1.50	-	1.50	-	Stick	Stick	FLAPS UP FLAPS DOWN
	TruTrak	ADI	2					-	-	-
	Autopilot – Indicator	TruTrak	2	0.50	0.50	1.50	1.50	OFF-ON	(1-3)	AUTOPILOT MASTER
	Auto Pilot – Servo	TruTrak	7.5	1.00	1.00					
	Intercom and Tone		1	0.30	0.30	0.30	0.30	-	-	-
EFIS	AFS3500	3	2.00	2.00	2.00	2.00	OFF-ON	(1-3)	EFIS Master	
			9.83	4.98						
BATT BUS	LEFT IGNITION	P-MAG		0.25	0.25	0.25	0.25	OFF-ON	(1-3)	LEFT P-MAG
	RIGHT IGNITION	FUTURE						OFF-ON	(1-3)	RIGHT P-MAG
	HOBBS							-	-	-
	CLOCK							-	-	-
			Total Loads	49.33	38.48	10.08	5.23			