



P. O. Box 728 • Caldwell, Idaho 83606
Tel: (208) 454-2600 Fax (208) 454-8608

SERVICE LETTER

SUBJECT: Possible damage to turtle deck.

COMPLIANCE: Immediately on aircraft now flying or before first flight.

EXPLANATION: It has come to our attention that some builders are not providing adequate edge distance at the rear most edge of the Lexan skylight. The leading edge of the turtle deck must engage the skylight with a minimum overlap of 1 1/4".

ACTION: If you have not yet installed your skylight, refer to figure 1. Note, the edge distance on the skylight must be at least 1 1/4".

If your skylight has been installed, check to see that the minimum edge distance requirement has been met. If after inspection it is determined that you have inadequate edge distance, refer to Figure 2.

SUMMARY: Compliance with this service letter should eliminate any possibility of turtle deck damage. Slips with door open should be avoided as they may aggravate this problem, by pressurizing the rear fuselage area.

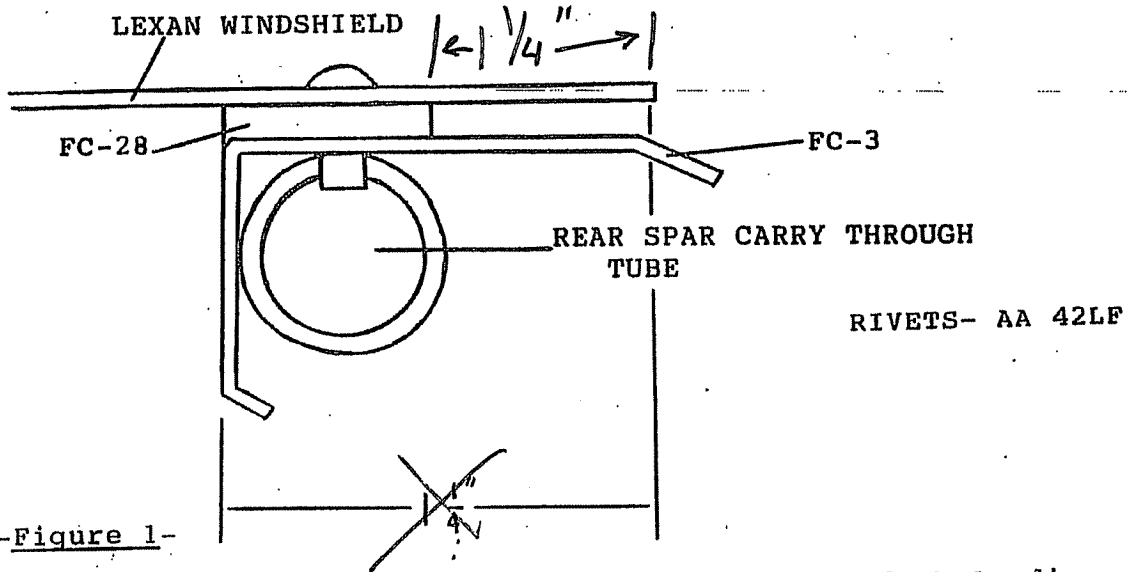

-Figure 1-

To ensure proper engagement of the turtle deck leading edge under the Lexan skylight, see that a minimum of 1 1/4" of skylight extends off as measured from the ~~front edge~~ **BACK EDGE** of FC-3 to the rear edge of the Lexan. **OF FC-28**

I MARKED THIS UP PER THE EXPLANATION ON THE SERVICE LETTER. I HAVE SEEN MANY TIMES WHERE THE ILLUSTRATOR DOES NOT PROPERLY DRAW WHAT SHOULD BE SHOWN... JUST MY SNAKE OIL BUT I SLIP THE CRAP OUTA MY PLANE WITH 1 1/4" OVERLAP AND HAVE NEVER TOPPED THE DECK OFF.

SNAKE

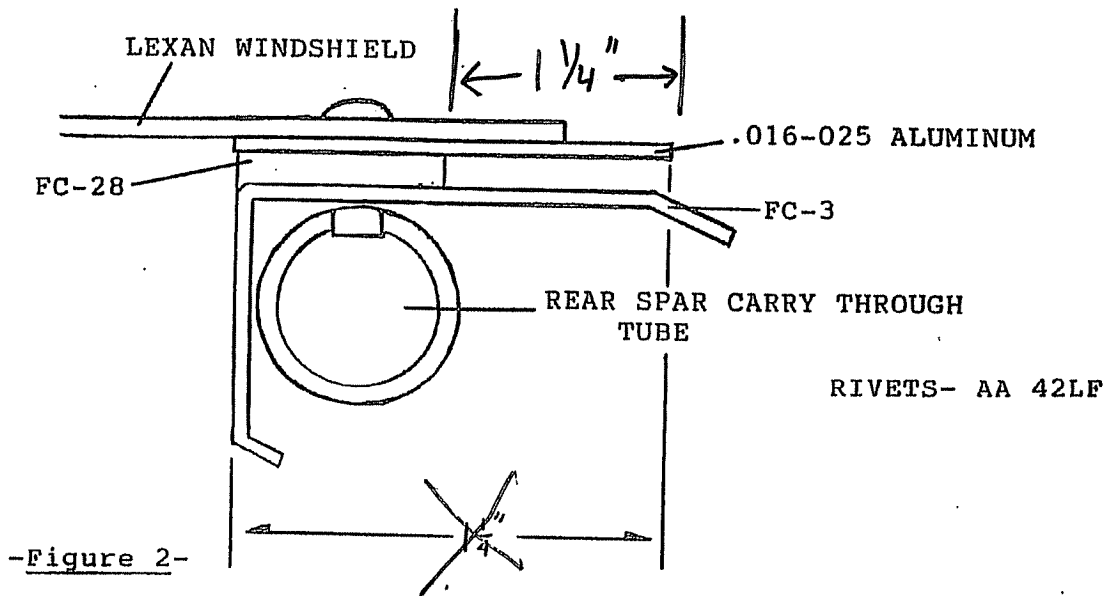

- A. Remove rivets attaching the Lexan to the rear spar carry through tube.
- B. Install an aluminum strip .016-025-thick, between PN FC-28 and the Lexan windshield ensuring a minimum of 1 1/4" length as measured ~~from the front edge of FC 3 to the rear most edge of the aluminum strip.~~
- C. Install rivets, check turtle deck fit.